

# 1b. NP-completeness

## COMP6741: Parameterized and Exact Computation

Serge Gaspers

19T3

### Contents

1	Overview	1
2	Turing Machines, P, and NP	2
3	Reductions and NP-completeness	5
4	NP-complete problems	6
5	Further Reading	8

## 1 Overview

### Polynomial-time algorithm

Polynomial-time algorithm: There exists a constant  $c \in \mathbb{N}$  such that the algorithm has (worst-case) running-time  $O(n^c)$ , where  $n$  is the size of the input.

### Example

Polynomial:  $n$ ;  $n^2 \log_2 n$ ;  $n^3$ ;  $n^{20}$  Super-polynomial:  $n^{\log_2 n}$ ;  $2^{\sqrt{n}}$ ;  $1.001^n$ ;  $2^n$ ;  $n!$

### Central Question

Which computational problems have polynomial-time algorithms?

### Million-dollar question

Intriguing class of problems: NP-complete problems.

### NP-complete problems

It is unknown whether NP-complete problems have polynomial-time algorithms.

- A polynomial-time algorithm for one NP-complete problem would imply polynomial-time algorithms for all problems in NP.

Gerhard Woeginger's P vs NP page: <http://www.win.tue.nl/~gwoegi/P-versus-NP.htm>

### Polynomial vs. NP-complete

Polynomial

- SHORTEST PATH: Given a graph  $G$ , two vertices  $a$  and  $b$  of  $G$ , and an integer  $k$ , does  $G$  have a simple  $a$ - $b$ -path of length at most  $k$ ?
- EULER TOUR: Given a graph  $G$ , does  $G$  have a cycle that traverses each edge of  $G$  exactly once?

- 2-CNF SAT: Given a propositional formula  $F$  in 2-CNF, is  $F$  satisfiable? A  $k$ -CNF formula is a conjunction (AND) of clauses, and each clause is a disjunction (OR) of at most  $k$  literals, which are negated or unnegated Boolean variables.

NP-complete

- LONGEST PATH: Given a graph  $G$  and an integer  $k$ , does  $G$  have a simple path of length at least  $k$ ?
- HAMILTONIAN CYCLE: Given a graph  $G$ , does  $G$  have a simple cycle that visits each vertex of  $G$ ?
- 3-CNF SAT: Given a propositional formula  $F$  in 3-CNF, is  $F$  satisfiable? Example:  $(x \vee \neg y \vee z) \wedge (\neg x \vee z) \wedge (\neg y \vee \neg z)$ .

## Overview

What's next?

- Formally define P, NP, and NP-complete (NPC)
- (New) skill: show that a problem is NP-complete

## 2 Turing Machines, P, and NP

### Decision problems and Encodings

<Name of Decision Problem>  
 Input: <What constitutes an instance>  
 Question: <Yes/No question>

We want to know which decision problems can be solved in polynomial time – polynomial in the *size of the input*  $n$ .

- Assume a “reasonable” encoding of the input
- Many encodings are polynomial-time equivalent; i.e., one encoding can be computed from another in polynomial time.
- Important exception: unary versus binary encoding of integers.
  - An integer  $x$  takes  $\lceil \log_2 x \rceil$  bits in binary and  $x = 2^{\log_2 x}$  bits in unary.

### Formal-language framework

We can view decision problems as languages.

- Alphabet  $\Sigma$ : finite set of symbols. W.l.o.g.,  $\Sigma = \{0, 1\}$
- Language  $L$  over  $\Sigma$ : set of strings made with symbols from  $\Sigma$ :  $L \subseteq \Sigma^*$
- Fix an encoding of instances of a decision problem  $\Pi$  into  $\Sigma$
- Define the language  $L_\Pi \subseteq \Sigma^*$  such that

$$x \in L_\Pi \Leftrightarrow x \text{ is a Yes-instance for } \Pi$$

## Non-deterministic Turing Machine (NTM)

- *input word*  $x \in \Sigma^*$  placed on an *infinite tape* (memory)
- read-write head initially placed on the first symbol of  $x$
- computation step: if the machine is in state  $s$  and reads  $a$ , it can move into state  $s'$ , writing  $b$ , and moving the head into direction  $D \in \{L, R\}$  if  $((s, a), (s', b, D)) \in \delta$ .

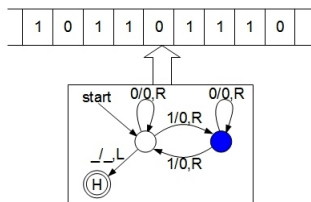

- $Q$ : finite, non-empty set of states
- $\Gamma$ : finite, non-empty set of tape symbols
- $\_ \in \Gamma$ : blank symbol (the only symbol allowed to occur on the tape infinitely often)
- $\Sigma \subseteq \Gamma \setminus \{b\}$ : set of input symbols
- $q_0 \in Q$ : start state
- $A \subseteq Q$ : set of accepting (final) states
- $\delta \subseteq (Q \setminus A \times \Gamma) \times (Q \times \Gamma \times \{L, R\})$ : transition relation, where  $L$  stands for a move to the left and  $R$  for a move to the right.

## Accepted Language

**Definition 1.** A NTM *accepts* a word  $x \in \Sigma^*$  if there exists a sequence of computation steps starting in the start state and ending in an accept state.

**Definition 2.** The language *accepted* by an NTM is the set of words it accepts.

## Video

The LEGO Turing Machine <https://www.youtube.com/watch?v=cYw2ewo06c4>

## Accept and Decide in polynomial time

**Definition 3.** A language  $L$  is *accepted in polynomial time* by an NTM  $M$  if

- $L$  is accepted by  $M$ , and
- there is a constant  $k$  such that for any word  $x \in L$ , the NTM  $M$  accepts  $x$  in  $O(|x|^k)$  computation steps.

**Definition 4.** A language  $L$  is *decided in polynomial time* by an NTM  $M$  if

- there is a constant  $k$  such that for any word  $x \in L$ , the NTM  $M$  accepts  $x$  in  $O(|x|^k)$  computation steps, and
- there is a constant  $k'$  such that for any word  $x \in \Sigma^* \setminus L$ , on input  $x$  the NTM  $M$  halts in a non-accepting state ( $Q \setminus A$ ) in  $O(|x|^{k'})$  computation steps.

## Deterministic Turing Machine

**Definition 5.** A *Deterministic Turing Machine (DTM)* is a Non-deterministic Turing Machine where the transition relation contains at most one tuple  $((s, a), (\cdot, \cdot, \cdot))$  for each  $s \in Q \setminus A$  and  $a \in \Gamma$ .

The transition relation  $\delta$  can be viewed as a function  $\delta : Q \setminus A \times \Gamma \rightarrow Q \times \Gamma \times \{L, R\}$ .  $\Rightarrow$  For a given input word  $x \in \Sigma^*$ , there is exactly one sequence of computation steps starting in the start state.

## DTM equivalents

Many computational models are polynomial-time equivalent to DTMs:

- Random Access Machine (RAM, used for algorithms in the textbook)
- variants of Turing machines (multiple tapes, infinite only in one direction, ...)
- ...

## P and NP

**Definition 6 (P).**  $P = \{L \subseteq \Sigma^* : \text{there is a DTM accepting } L \text{ in polynomial time}\}$

**Definition 7 (NP).**  $NP = \{L \subseteq \Sigma^* : \text{there is a NTM accepting } L \text{ in polynomial time}\}$

**Definition 8 (coNP).**  $\text{coNP} = \{L \subseteq \Sigma^* : \Sigma^* \setminus L \in NP\}$

## coP?

**Theorem 9.**  $P = \{L \subseteq \Sigma^* : \text{there is a DTM deciding } L \text{ in polynomial time}\}$

*Proof sketch.* Need to show: if  $L$  is accepted by a DTM  $M$  in polynomial time, then there is a DTM that decides  $L$  in polynomial time. Idea: design a DTM  $M'$  that simulates  $M$  for  $c \cdot n^k$  steps, where  $c \cdot n^k$  is the running time of  $M$ . (Note that this proof is nonconstructive: we might not know the running time of  $M$ .)  $\square$

## NP and certificates

### Non-deterministic choices

A NTM for an NP-language  $L$  makes a polynomial number of non-deterministic choices on input  $x \in L$ . We can encode these non-deterministic choices into a *certificate*  $c$ , which is a polynomial-length word. Now, there exists a DTM, which, given  $x$  and  $c$ , verifies that  $x \in L$  in polynomial time.

Thus,  $L \in NP$  iff there is a DTM  $V$  and for each  $x \in L$  there exists a polynomial-length certificate  $c$  such that  $V(x, c) = 1$ , but  $V(y, \cdot) = 0$  for each  $y \notin L$ .

## CNF-SAT is in NP

- A *CNF formula* is a propositional formula in conjunctive normal form: a conjunction (AND) of clauses; each clause is a disjunction (OR) of literals; each literal is a negated or unnegated Boolean variable.
- An assignment  $\alpha : \text{var}(F) \rightarrow \{0, 1\}$  satisfies a clause  $C$  if it sets a literal of  $C$  to true, and it satisfies  $F$  if it satisfies all clauses in  $F$ .

CNF-SAT

Input: CNF formula  $F$

Question: Does  $F$  have a satisfying assignment?

Example:  $(x \vee \neg y \vee z) \wedge (\neg x \vee z) \wedge (\neg y \vee \neg z)$ .

**Lemma 10.**  $\text{CNF-SAT} \in NP$ .

*Proof.* Certificate: assignment  $\alpha$  to the variables. Given a certificate, it can be checked in polynomial time whether all clauses are satisfied.  $\square$

## Brute-force algorithms for problems in NP

**Theorem 11.** *Every problem in NP can be solved in exponential time.*

*Proof.* Let  $\Pi$  be an arbitrary problem in NP. [Use certificate-based definition of NP] We know that  $\exists$  a polynomial  $p$  and a polynomial-time verification algorithm  $V$  such that:

- for every  $x \in \Pi$  (i.e., every YES-instance for  $\Pi$ )  $\exists$  string  $c \in \{0, 1\}^*$ ,  $|c| \leq p(|x|)$ , such that  $V(x, c) = 1$ , and
- for every  $x \notin \Pi$  (i.e., every NO-instance for  $\Pi$ ) and every string  $c \in \{0, 1\}^*$ ,  $V(x, c) = 0$ .

Now, we can prove that there exists an exponential-time algorithm for  $\Pi$  with input  $x$ :

- For each string  $c \in \{0, 1\}^*$  with  $|c| \leq p(|x|)$ , evaluate  $V(x, c)$  and return YES if  $V(x, c) = 1$ .
- Return NO.

Running time:  $2^{p(|x|)} \cdot n^{O(1)} \subseteq 2^{O(2 \cdot p(|x|))} = 2^{O(p(|x|))}$ , but non-constructive.  $\square$

## 3 Reductions and NP-completeness

### Polynomial-time reduction

**Definition 12.** A language  $L_1$  is *polynomial-time reducible* to a language  $L_2$ , written  $L_1 \leq_P L_2$ , if there exists a polynomial-time computable function  $f : \Sigma^* \rightarrow \Sigma^*$  such that for all  $x \in \Sigma^*$ ,

$$x \in L_1 \Leftrightarrow f(x) \in L_2.$$

A polynomial time algorithm computing  $f$  is a *reduction algorithm*.

### New polynomial-time algorithms via reductions

**Lemma 13.** *If  $L_1, L_2 \in \Sigma^*$  are languages such that  $L_1 \leq_P L_2$ , then  $L_2 \in P$  implies  $L_1 \in P$ .*

### NP-completeness

**Definition 14** (NP-hard). A language  $L \subseteq \Sigma^*$  is *NP-hard* if

$$L' \leq_P L \text{ for every } L' \in \text{NP}.$$

**Definition 15** (NP-complete). A language  $L \subseteq \Sigma^*$  is *NP-complete* (in NPC) if

1.  $L \in \text{NP}$ , and
2.  $L$  is NP-hard.

### A first NP-complete problem

**Theorem 16.** *CNF-SAT is NP-complete.*

Proved by encoding NTMs into SAT [Coo71; Lev73] and then CNF-SAT [Kar72].

### Proving NP-completeness

**Lemma 17.** *If  $L$  is a language such that  $L' \leq_P L$  for some  $L' \in \text{NPC}$ , then  $L$  is NP-hard. If, in addition,  $L \in \text{NP}$ , then  $L \in \text{NPC}$ .*

*Proof.* For all  $L'' \in \text{NP}$ , we have  $L'' \leq_P L' \leq_P L$ . By transitivity, we have  $L'' \leq_P L$ . Thus,  $L$  is NP-hard.  $\square$

## Proving NP-completeness (2)

Method to prove that a language  $L$  is NP-complete:

1. Prove  $L \in \text{NP}$
2. Prove  $L$  is NP-hard.
  - Select a known NP-complete language  $L'$ .
  - Describe an algorithm that computes a function  $f$  mapping every instance  $x \in \Sigma^*$  of  $L'$  to an instance  $f(x)$  of  $L$ .
  - Prove that  $x \in L' \Leftrightarrow f(x) \in L$  for all  $x \in \Sigma^*$ .
  - Prove that the algorithm computing  $f$  runs in polynomial time.

## 4 NP-complete problems

### 3-CNF SAT is NP-hard

**Theorem 18.** *3-CNF SAT is NP-complete.*

*Proof.* 3-CNF SAT is in NP, since it is a special case of CNF-SAT. To show that 3-CNF SAT is NP-hard, we give a polynomial reduction from CNF-SAT. Let  $F$  be a CNF formula. The reduction algorithm constructs a 3-CNF formula  $F'$  as follows. For each clause  $C$  in  $F$ :

- If  $C$  has at most 3 literals, then copy  $C$  into  $F'$ .
- Otherwise, denote  $C = (\ell_1 \vee \ell_2 \vee \dots \vee \ell_k)$ . Create  $k - 3$  new variables  $y_1, \dots, y_{k-3}$ , and add the clauses  $(\ell_1 \vee \ell_2 \vee y_1), (\neg y_1 \vee \ell_3 \vee y_2), (\neg y_2 \vee \ell_4 \vee y_3), \dots, (\neg y_{k-3} \vee \ell_{k-1} \vee \ell_k)$ .

Show that  $F$  is satisfiable  $\Leftrightarrow F'$  is satisfiable. Show that  $F'$  can be computed in polynomial time (trivial; use a RAM).  $\square$

### Clique

A *clique* in a graph  $G = (V, E)$  is a subset of vertices  $S \subseteq V$  such that every two vertices of  $S$  are adjacent in  $G$ .

CLIQUE

Input: Graph  $G$ , integer  $k$   
 Question: Does  $G$  have a clique of size  $k$ ?

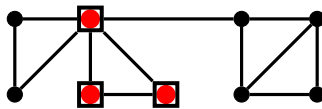

**Theorem 19.** *CLIQUE is NP-complete.*

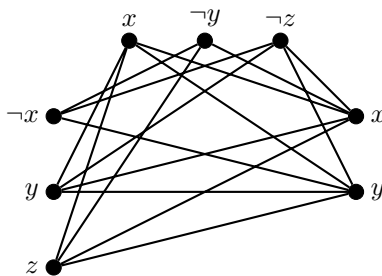

$$(\neg x \vee y \vee z) \wedge (x \vee \neg y \vee \neg z) \wedge (x \vee y)$$

- CLIQUE is in NP

- Let  $F = C_1 \wedge C_2 \wedge \dots \wedge C_k$  be a 3-CNF formula
- Construct a graph  $G$  that has a clique of size  $k$  iff  $F$  is satisfiable
- For each clause  $C_r = (\ell_1^r \vee \dots \vee \ell_w^r)$ ,  $1 \leq r \leq k$ , create  $w$  new vertices  $v_1^r, \dots, v_w^r$
- Add an edge between  $v_i^r$  and  $v_j^s$  if

$$r \neq s \quad \text{and} \\ \ell_i^r \neq \neg \ell_j^s \quad \text{where } \neg \neg x = x.$$

- Check correctness and polynomial running time
- Correctness:  $F$  has a satisfying assignment iff  $G$  has a clique of size  $k$ .
- ( $\Rightarrow$ ): Let  $\alpha$  be a sat. assignment for  $F$ . For each clause  $C_r$ , choose a literal  $\ell_i^r$  with  $\alpha(\ell_i^r) = 1$ , and denote by  $s^r$  the corresponding vertex in  $G$ . Now,  $\{s^r : 1 \leq r \leq k\}$  is a clique of size  $k$  in  $G$  since  $\alpha(x) \neq \alpha(\neg x)$ .
- ( $\Leftarrow$ ): Let  $S$  be a clique of size  $k$  in  $G$ . Then,  $S$  contains exactly one vertex  $s_r \in \{v_1^r, \dots, v_w^r\}$  for each  $r \in \{1, \dots, k\}$ . Denote by  $l^r$  the corresponding literal. Now, for any  $r, r'$ , it is not the case that  $l_r = \neg l_{r'}$ . Therefore, there is an assignment  $\alpha$  to  $\text{var}(F)$  such that  $\alpha(l_r) = 1$  for each  $r \in \{1, \dots, k\}$  and  $\alpha$  satisfies  $F$ .

### Vertex Cover

A *vertex cover* in a graph  $G = (V, E)$  is a subset of vertices  $S \subseteq V$  such that every edge of  $G$  has an endpoint in  $S$ .

#### VERTEX COVER

Input: Graph  $G$ , integer  $k$   
 Question: Does  $G$  have a vertex cover of size  $k$ ?

**Theorem 20.** VERTEX COVER is NP-complete.

Exercise Sheet 1b.

### Hamiltonian Cycle

A *Hamiltonian Cycle* in a graph  $G = (V, E)$  is a cycle visiting each vertex exactly once. (Alternatively, a permutation of  $V$  such that every two consecutive vertices are adjacent and the first and last vertex in the permutation are adjacent.)

#### HAMILTONIAN CYCLE

Input: Graph  $G$   
 Question: Does  $G$  have a Hamiltonian Cycle?

**Theorem 21.** HAMILTONIAN CYCLE is NP-complete.

*Proof sketch.* • HAMILTONIAN CYCLE is in NP: the certificate is a Hamiltonian Cycle of  $G$ .

- Let us show: VERTEX COVER  $\leq_P$  HAMILTONIAN CYCLE
- Let  $(G = (V, E), k)$  be an instance for VERTEX COVER (VC).
- We will construct an equivalent instance  $G'$  for HAMILTONIAN CYCLE (HC).
- Intuition: Non-deterministic choices
  - for VC: which vertices to select in the vertex cover
  - for HC: which route the cycle takes
- Add  $k$  vertices  $s_1, \dots, s_k$  to  $G'$  (*selector vertices*)
- Each edge of  $G$  will be represented by a gadget (subgraph) of  $G'$

- s.t. the set of edges covered by a vertex  $x$  in  $G$  corresponds to a partial cycle going through all gadgets of  $G'$  representing these edges.

- Attention: we need to allow for an edge to be covered by both endpoints

Gadget representing the edge  $\{u, v\} \in E$  Its states: 'covered by  $u$ ', 'covered by  $u$  and  $v$ ', 'covered by  $v$ '

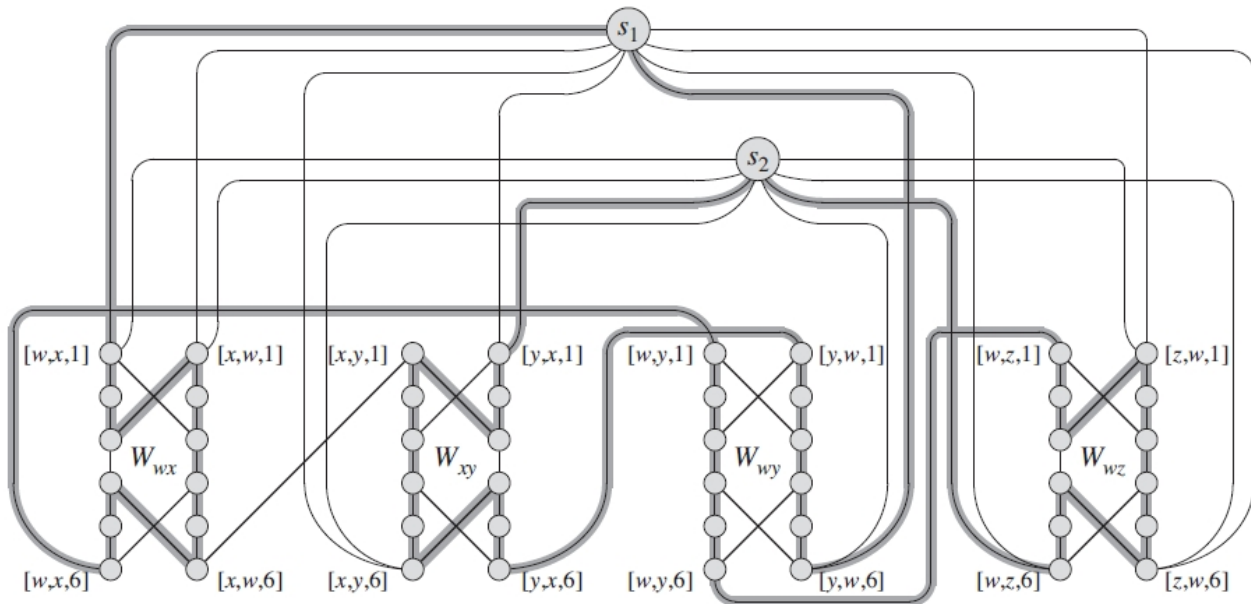
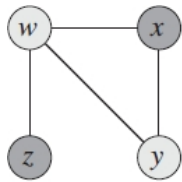
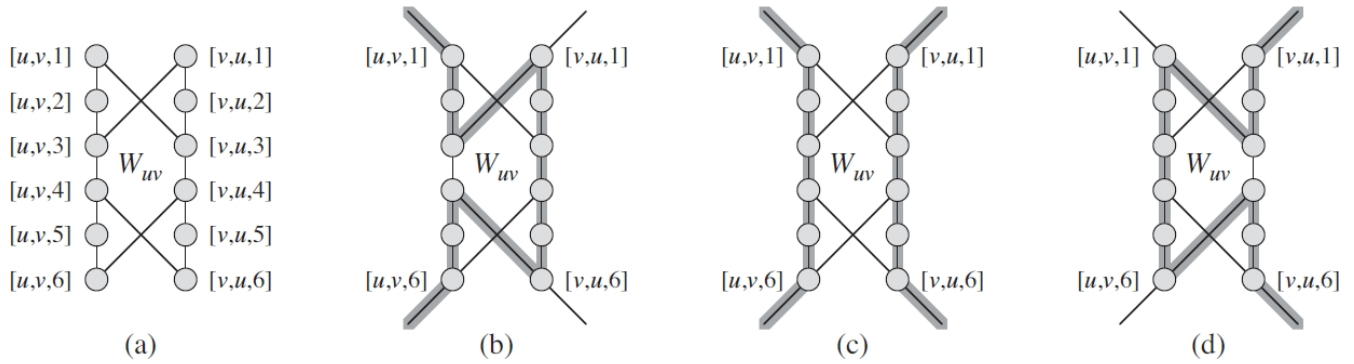

## 5 Further Reading

- Chapter 34, NP-Completeness, in [Cor+09]
- Garey and Johnson's influential reference book [GJ79]



## References

- [Coo71] Stephen A. Cook. “The Complexity of Theorem-Proving Procedures”. In: *Proceedings of the 3rd Annual ACM Symposium on Theory of Computing (STOC 1971)*. 1971, pp. 151–158.
- [Cor+09] Thomas H. Cormen, Charles E. Leiserson, Ronald L. Rivest, and Clifford Stein. *Introduction to Algorithms*. 3rd ed. The MIT Press, 2009.
- [GJ79] Michael R. Garey and David S. Johnson. *Computers and Intractability: A Guide to the Theory of NP-Completeness*. W. H. Freeman & Co., 1979.
- [Kar72] Richard M. Karp. “Reducibility among combinatorial problems”. In: *Complexity of computer computations (Proc. Sympos., IBM Thomas J. Watson Res. Center, Yorktown Heights, N.Y., 1972)*. New York: Plenum, 1972, pp. 85–103.
- [Lev73] Leonid Levin. “Universal sequential search problems”. In: *Problems of Information Transmission* 9.3 (1973), pp. 265–266.