

8. Parameterized intractability: the W-hierarchy

COMP6741: Parameterized and Exact Computation

Serge Gaspers^{1,2}

¹School of Computer Science and Engineering, UNSW Australia

²Data61, Decision Sciences Group, CSIRO

Semester 2, 2016

- 1 Reminder: Polynomial Time Reductions and NP-completeness
- 2 Parameterized Complexity Theory
 - Parameterized reductions
 - Parameterized complexity classes
- 3 Case studies
- 4 Further Reading

- 1 Reminder: Polynomial Time Reductions and NP-completeness
- 2 Parameterized Complexity Theory
 - Parameterized reductions
 - Parameterized complexity classes
- 3 Case studies
- 4 Further Reading

Definition 1

A **polynomial-time reduction** from a decision problem Π_1 to a decision problem Π_2 is a polynomial-time algorithm, which, for any instance of Π_1 produces an equivalent instance of Π_2 .

If there exists a polynomial-time reduction from Π_1 to Π_2 , we say that Π_1 is **polynomial-time reducible** to Π_2 and write $\Pi_1 \leq_P \Pi_2$.

Lemma 2

If Π_1, Π_2 are decision problems such that $\Pi_1 \leq_P \Pi_2$, then $\Pi_2 \in P$ implies $\Pi_1 \in P$.

Definition 3 (NP-hard)

A decision problem Π is **NP-hard** if $\Pi' \leq_P \Pi$ for every $\Pi' \in \text{NP}$.

Definition 4 (NP-complete)

A decision problem Π is **NP-complete** (in **NPC**) if

- 1 $\Pi \in \text{NP}$, and
- 2 Π is **NP-hard**.

Lemma 5

If Π is a decision problem such that $\Pi' \leq_P \Pi$ for some NP-hard decision problem Π' , then Π is NP-hard.

If, in addition, $\Pi \in \text{NP}$, then $\Pi \in \text{NPC}$.

Proving NP-completeness II

Method to prove that a decision problem Π is NP-complete:

- 1 Prove $\Pi \in \text{NP}$
- 2 Prove Π is NP-hard.
 - Select a known NP-hard decision problem Π' .
 - Describe an algorithm that transforms every instance I of Π' to an instance $r(I)$ of Π .
 - Prove that for each instance I of Π' , we have that I is a YES-instance of $\Pi' \Leftrightarrow r(I)$ is a YES-instance of Π .
 - Show that the algorithm runs in polynomial time.

- 1 Reminder: Polynomial Time Reductions and NP-completeness
- 2 **Parameterized Complexity Theory**
 - Parameterized reductions
 - Parameterized complexity classes
- 3 Case studies
- 4 Further Reading

Main Parameterized Complexity Classes

n : instance size

k : parameter

P: class of problems that can be solved in $n^{O(1)}$ time

FPT: class of parameterized problems that can be solved in $f(k) \cdot n^{O(1)}$ time

W[.]: parameterized intractability classes

XP: class of parameterized problems that can be solved in $f(k) \cdot n^{g(k)}$ time
("polynomial when k is a constant")

$$\mathbf{P} \subseteq \mathbf{FPT} \subseteq \mathbf{W[1]} \subseteq \mathbf{W[2]} \cdots \subseteq \mathbf{W[P]} \subseteq \mathbf{XP}$$

Note: We assume that f is **computable** and **non-decreasing**.

Polynomial-time reductions for parameterized problems?

A **vertex cover** in a graph $G = (V, E)$ is a subset of vertices $S \subseteq V$ such that every edge of G has an endpoint in S .

VERTEX COVER

Input: Graph G , integer k

Parameter: k

Question: Does G have a vertex cover of size k ?

An **independent set** in a graph $G = (V, E)$ is a subset of vertices $S \subseteq V$ such that there is no edge $uv \in E$ with $u, v \in S$.

INDEPENDENT SET

Input: Graph G , integer k

Parameter: k

Question: Does G have an independent set of size k ?

Polynomial-time reductions for parameterized problems?

A **vertex cover** in a graph $G = (V, E)$ is a subset of vertices $S \subseteq V$ such that every edge of G has an endpoint in S .

VERTEX COVER

Input: Graph G , integer k

Parameter: k

Question: Does G have a vertex cover of size k ?

An **independent set** in a graph $G = (V, E)$ is a subset of vertices $S \subseteq V$ such that there is no edge $uv \in E$ with $u, v \in S$.

INDEPENDENT SET

Input: Graph G , integer k

Parameter: k

Question: Does G have an independent set of size k ?

- We know: $\text{INDEPENDENT SET} \leq_p \text{VERTEX COVER}$
- However: $\text{VERTEX COVER} \in \text{FPT}$ but INDEPENDENT SET is not known to be in FPT

We will need another type of reductions

- Issue with polynomial-time reductions: parameter can change arbitrarily

We will need another type of reductions

- Issue with polynomial-time reductions: parameter can change arbitrarily
- We will want the reduction to produce an instance where the parameter is bounded by a function of the original instance

We will need another type of reductions

- Issue with polynomial-time reductions: parameter can change arbitrarily
- We will want the reduction to produce an instance where the parameter is bounded by a function of the original instance
- Also: we can allow the reduction to take **FPT** time instead of only polynomial time.

- 1 Reminder: Polynomial Time Reductions and NP-completeness
- 2 **Parameterized Complexity Theory**
 - Parameterized reductions
 - Parameterized complexity classes
- 3 Case studies
- 4 Further Reading

Definition 6

A **parameterized reduction** from a parameterized decision problem Π_1 to a parameterized decision problem Π_2 is an algorithm, which, for any instance I of Π_1 with parameter k produces an instance I' of Π_2 with parameter k' such that

- I is a **YES**-instance for $\Pi_1 \Leftrightarrow I'$ is a **YES**-instance for Π_2 ,
- there exists a computable function g such that $k' \leq g(k)$, and
- there exists a computable function f such that the running time of the algorithm is $f(k) \cdot |I|^{O(1)}$.

If there exists a parameterized reduction from Π_1 to Π_2 , we write $\Pi_1 \leq_{\text{FPT}} \Pi_2$.

Note: We can assume that f and g are non-decreasing.

New FPT algorithms via reductions

Lemma 7

If Π_1, Π_2 are parameterized decision problems such that $\Pi_1 \leq_{\text{FPT}} \Pi_2$, then $\Pi_2 \in \text{FPT}$ implies $\Pi_1 \in \text{FPT}$.

Proof sketch.

To obtain an FPT algorithm for Π_1 , perform the reduction and then use an FPT algorithm for Π_2 on the resulting instance. □

- 1 Reminder: Polynomial Time Reductions and NP-completeness
- 2 **Parameterized Complexity Theory**
 - Parameterized reductions
 - **Parameterized complexity classes**
- 3 Case studies
- 4 Further Reading

Definition 8

A **Boolean circuit** is a directed acyclic graph with the nodes labeled as follows:

- every node of in-degree 0 is an **input node**,
- every node with in-degree 1 is a **negation node** (\neg), and
- every node with in-degree ≥ 2 is either an **AND-node** (\wedge) or an **OR-node** (\vee).

Moreover, exactly one node with out-degree 0 is also labeled the **output node**.

The **depth** of the circuit is the maximum length of a directed path from an input node to the output node.

The **weft** of the circuit is the maximum number of nodes with in-degree ≥ 3 on a directed path from an input node to the output node.

Example

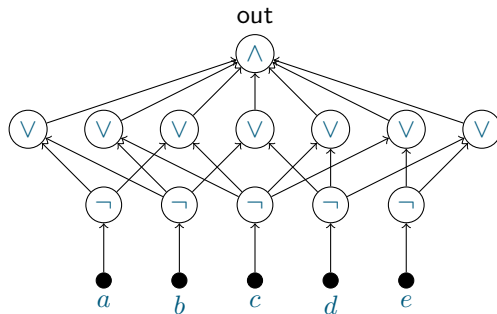

A depth-3, width-1 Boolean circuit with inputs a, b, c, d, e .

Weighted Circuit Satisfiability

Given an assignment of Boolean values to the input gates, the circuit determines Boolean values at each node in the obvious way.

If the value of the output node is 1 for an input assignment, we say that this assignment **satisfies** the circuit.

The **weight** of an assignment is its number of 1s.

WEIGHTED CIRCUIT SATISFIABILITY (WCS)

Input: A Boolean circuit C , an integer k

Parameter: k

Question: Is there an assignment with weight k that satisfies C ?

Exercise: Show that WEIGHTED CIRCUIT SATISFIABILITY $\in XP$.

Definition 9

The class of circuits $\mathcal{C}_{t,d}$ contains the circuits with $\text{width} \leq t$ and $\text{depth} \leq d$.

For any class of circuits \mathcal{C} , we can define the following problem.

WCS[\mathcal{C}]

Input: A Boolean circuit $C \in \mathcal{C}$, an integer k

Parameter: k

Question: Is there an assignment with weight k that satisfies C ?

Definition 10 (W-hierarchy)

Let $t \in \{1, 2, \dots\}$. A parameterized problem Π is in the parameterized complexity class $W[t]$ if there exists a parameterized reduction from Π to $WCS[\mathcal{C}_{t,d}]$ for some constant $d \geq 1$.

Independent Set and Dominating Set

Theorem 11

INDEPENDENT SET $\in W[1]$.

Theorem 12

DOMINATING SET $\in W[2]$.

Recall: A **dominating set** of a graph $G = (V, E)$ is a set of vertices $S \subseteq V$ such that $N_G[S] = V$.

DOMINATING SET

Input: A graph $G = (V, E)$ and an integer k

Parameter: k

Question: Does G have a dominating set of size at most k ?

“Proof” by picture

Parameterized reductions from INDEPENDENT SET to $WCS[\mathcal{C}_{1,3}]$ and from DOMINATING SET to $WCS[\mathcal{C}_{2,2}]$.

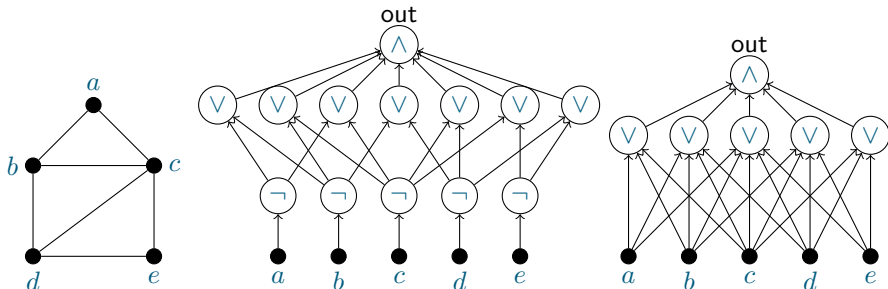

Setting an input node to 1 corresponds to adding the corresponding vertex to the independent set / dominating set.

Definition 13

Let $t \in \{1, 2, \dots\}$.

A parameterized decision problem Π is **W[t]-hard** if for every parameterized decision problem Π' in **W[t]**, there is a parameterized reduction from Π' to Π .

Π is **W[t]-complete** if $\Pi \in \mathbf{W}[t]$ and Π is **W[t]-hard**.

It has been proved that INDEPENDENT SET is **W[1]-hard** and DOMINATING SET is **W[2]-hard**. Therefore,

Theorem 14

INDEPENDENT SET is **W[1]-complete**.

Theorem 15

DOMINATING SET is **W[2]-complete**.

To show that a parameterized decision problem Π is $W[t]$ -hard:

- Select a $W[t]$ -hard problem Π'
- Show that $\Pi' \leq_{\text{FPT}} \Pi$ by designing a parameterized reduction from Π' to Π
 - Design an algorithm, that, for any instance I' of Π' with parameter k' , produces an equivalent instance I of Π with parameter k
 - Show that k is upper bounded by a function of k'
 - Show that there exists a function f such that the running time of the algorithm is $f(k') \cdot |I'|^{O(1)}$

- 1 Reminder: Polynomial Time Reductions and NP-completeness
- 2 Parameterized Complexity Theory
 - Parameterized reductions
 - Parameterized complexity classes
- 3 Case studies
- 4 Further Reading

Clique

A **clique** in a graph $G = (V, E)$ is a subset of its vertices $S \subseteq V$ such that every two vertices from S are adjacent in G .

CLIQUE

Input: Graph $G = (V, E)$, integer k

Parameter: k

Question: Does G have a clique of size k ?

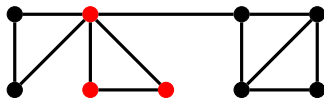

- We will show that CLIQUE is $W[1]$ -hard by a parameterized reduction from INDEPENDENT SET.

Clique is $W[1]$ -hard

Lemma 16

INDEPENDENT SET \leq_{FPT} CLIQUE.

Proof.

Given any instance $(G = (V, E), k)$ for INDEPENDENT SET, we need to describe an FPT algorithm that constructs an equivalent instance (G', k') for CLIQUE such that $k' \leq g(k)$ for some computable function g .

Clique is $W[1]$ -hard

Lemma 16

INDEPENDENT SET \leq_{FPT} CLIQUE.

Proof.

Given any instance $(G = (V, E), k)$ for INDEPENDENT SET, we need to describe an FPT algorithm that constructs an equivalent instance (G', k') for CLIQUE such that $k' \leq g(k)$ for some computable function g .

Construction. Set $k' \leftarrow k$ and $G' \leftarrow \overline{G} = (V, \{uv : u, v \in V, u \neq v, uv \notin E\})$.

Clique is $W[1]$ -hard

Lemma 16

INDEPENDENT SET \leq_{FPT} CLIQUE.

Proof.

Given any instance $(G = (V, E), k)$ for INDEPENDENT SET, we need to describe an FPT algorithm that constructs an equivalent instance (G', k') for CLIQUE such that $k' \leq g(k)$ for some computable function g .

Construction. Set $k' \leftarrow k$ and $G' \leftarrow \overline{G} = (V, \{uv : u, v \in V, u \neq v, uv \notin E\})$.

Equivalence. We need to show that (G, k) is a YES-instance for INDEPENDENT SET if and only if (G', k') is a YES-instance for CLIQUE.

Clique is $W[1]$ -hard

Lemma 16

INDEPENDENT SET \leq_{FPT} CLIQUE.

Proof.

Given any instance $(G = (V, E), k)$ for INDEPENDENT SET, we need to describe an FPT algorithm that constructs an equivalent instance (G', k') for CLIQUE such that $k' \leq g(k)$ for some computable function g .

Construction. Set $k' \leftarrow k$ and $G' \leftarrow \overline{G} = (V, \{uv : u, v \in V, u \neq v, uv \notin E\})$.

Equivalence. We need to show that (G, k) is a YES-instance for INDEPENDENT SET if and only if (G', k') is a YES-instance for CLIQUE.

(\Rightarrow) : Let S be an independent set of size k in G . For every two vertices $u, v \in S$, we have that $uv \notin E$. Therefore, $uv \in E(\overline{G})$ for every two vertices in S . We conclude that S is a clique of size k in \overline{G} .

Clique is $W[1]$ -hard

Lemma 16

INDEPENDENT SET \leq_{FPT} CLIQUE.

Proof.

Given any instance $(G = (V, E), k)$ for INDEPENDENT SET, we need to describe an FPT algorithm that constructs an equivalent instance (G', k') for CLIQUE such that $k' \leq g(k)$ for some computable function g .

Construction. Set $k' \leftarrow k$ and $G' \leftarrow \overline{G} = (V, \{uv : u, v \in V, u \neq v, uv \notin E\})$.

Equivalence. We need to show that (G, k) is a YES-instance for INDEPENDENT SET if and only if (G', k') is a YES-instance for CLIQUE.

(\Rightarrow) : Let S be an independent set of size k in G . For every two vertices $u, v \in S$, we have that $uv \notin E$. Therefore, $uv \in E(\overline{G})$ for every two vertices in S . We conclude that S is a clique of size k in \overline{G} .

(\Leftarrow) : Let S be a clique of size k in \overline{G} . By a similar argument, S is an independent set of size k in G .

Clique is $W[1]$ -hard

Lemma 16

INDEPENDENT SET \leq_{FPT} CLIQUE.

Proof.

Given any instance $(G = (V, E), k)$ for INDEPENDENT SET, we need to describe an FPT algorithm that constructs an equivalent instance (G', k') for CLIQUE such that $k' \leq g(k)$ for some computable function g .

Construction. Set $k' \leftarrow k$ and $G' \leftarrow \overline{G} = (V, \{uv : u, v \in V, u \neq v, uv \notin E\})$.

Equivalence. We need to show that (G, k) is a YES-instance for INDEPENDENT SET if and only if (G', k') is a YES-instance for CLIQUE.

(\Rightarrow) : Let S be an independent set of size k in G . For every two vertices $u, v \in S$, we have that $uv \notin E$. Therefore, $uv \in E(\overline{G})$ for every two vertices in S . We conclude that S is a clique of size k in \overline{G} .

(\Leftarrow) : Let S be a clique of size k in \overline{G} . By a similar argument, S is an independent set of size k in G .

Parameter. $k' \leq k$.

Clique is $W[1]$ -hard

Lemma 16

INDEPENDENT SET \leq_{FPT} CLIQUE.

Proof.

Given any instance $(G = (V, E), k)$ for INDEPENDENT SET, we need to describe an FPT algorithm that constructs an equivalent instance (G', k') for CLIQUE such that $k' \leq g(k)$ for some computable function g .

Construction. Set $k' \leftarrow k$ and $G' \leftarrow \overline{G} = (V, \{uv : u, v \in V, u \neq v, uv \notin E\})$.

Equivalence. We need to show that (G, k) is a YES-instance for INDEPENDENT SET if and only if (G', k') is a YES-instance for CLIQUE.

(\Rightarrow) : Let S be an independent set of size k in G . For every two vertices $u, v \in S$, we have that $uv \notin E$. Therefore, $uv \in E(\overline{G})$ for every two vertices in S . We conclude that S is a clique of size k in \overline{G} .

(\Leftarrow) : Let S be a clique of size k in \overline{G} . By a similar argument, S is an independent set of size k in G .

Parameter. $k' \leq k$.

Running time. The construction can clearly be done in FPT time, and even in polynomial time. □

Corollary 17

CLIQUE is $W[1]$ -hard

Recall: A k -coloring of a graph $G = (V, E)$ is a function $f : V \rightarrow \{1, 2, \dots, k\}$ assigning colors to V such that no two adjacent vertices receive the same color.

MULTICOLOR CLIQUE

Input: A graph $G = (V, E)$, an integer k , and a k -coloring of G
Parameter: k
Question: Does G have a clique of size k ?

- Show that MULTICOLOR CLIQUE is $W[1]$ -hard.

Exercise

A **set system** \mathcal{S} is a pair (V, H) , where V is a finite set of elements and H is a set of subsets of V .

A **set cover** of a set system $\mathcal{S} = (V, H)$ is a subset X of H such that each element of V is contained in at least one of the sets in X , i.e., $\bigcup_{Y \in X} Y = V$.

SET COVER

Input: A set system $\mathcal{S} = (V, H)$ and an integer k

Parameter: k

Question: Does \mathcal{S} have a set cover of cardinality at most k ?

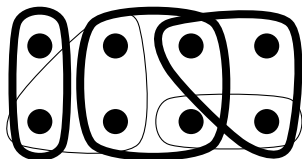

- Show that SET COVER is **W[2]**-hard.

Exercise

A **hitting set** of a set system $\mathcal{S} = (V, H)$ is a subset X of V such that X contains at least one element of each set in H , i.e., $X \cap Y \neq \emptyset$ for each $Y \in H$.

HITTING SET

Input: A set system $\mathcal{S} = (V, H)$ and an integer k

Parameter: k

Question: Does \mathcal{S} have a hitting set of size at most k ?

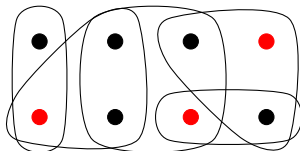

- Show that HITTING SET is $W[2]$ -hard.

- 1 Reminder: Polynomial Time Reductions and NP-completeness
- 2 Parameterized Complexity Theory
 - Parameterized reductions
 - Parameterized complexity classes
- 3 Case studies
- 4 Further Reading

- Chapter 13, *Fixed-parameter Intractability* in Marek Cygan, Fedor V. Fomin, Łukasz Kowalik, Daniel Lokshtanov, Dániel Marx, Marcin Pilipczuk, Michał Pilipczuk, and Saket Saurabh. *Parameterized Algorithms*. Springer, 2015.
- Chapter 13, *Parameterized Complexity Theory* in Rolf Niedermeier. *Invitation to Fixed Parameter Algorithms*. Oxford University Press, 2006.
- Elements of Chapters 20–23 in Rodney G. Downey and Michael R. Fellows. *Fundamentals of Parameterized Complexity*. Springer, 2013.