

Serial Input/Output

Lecturer: Sri Parameswaran

Notes By: Annie Guo

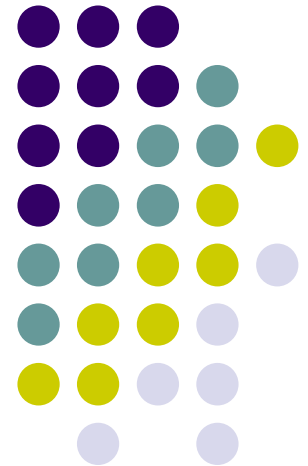

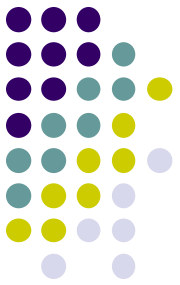

Lecture overview

- Serial communication
 - Concepts
 - Standards
- USART in AVR



Why Serial I/O?

- Problems with Parallel I/O:
 - Needs a wire for each bit.
 - When the source and destination are more than a few feet the parallel cable can be bulky and expensive.
 - Susceptible to reflections and induced noises for long distance communication.
- Serial I/O overcomes these problems.

Serial Communication System Structure

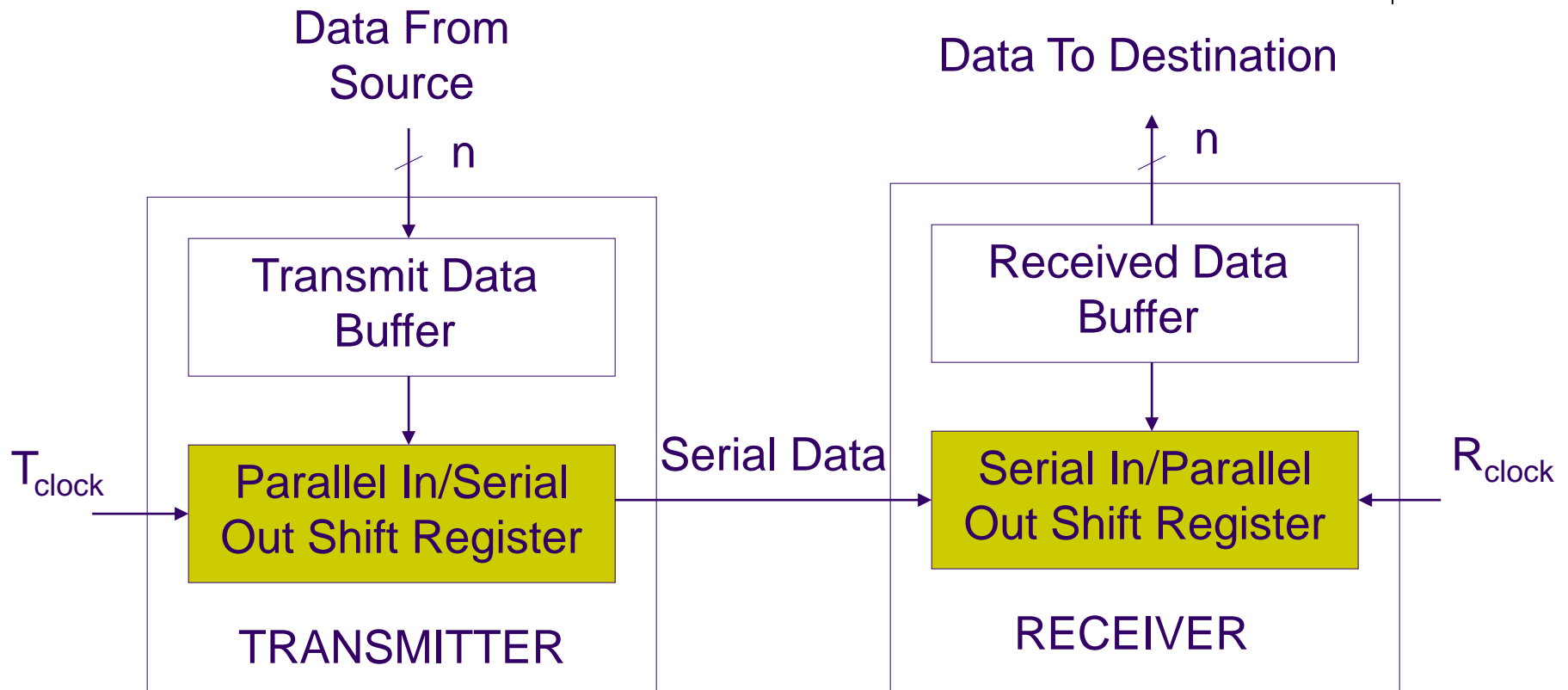
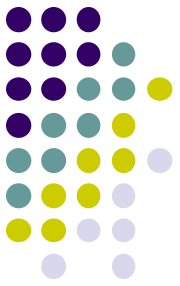

Serial Communication System Structure (cont.)

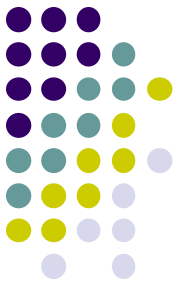

- At the communication source:
 - The parallel interface transfers data from the source to the transmit data buffer.
 - The data is loaded into the Parallel In Serial Out (PISO) register and T_{clock} shifts the data bits out from the shift register to the receiver.

Serial Communication System Structure (cont.)

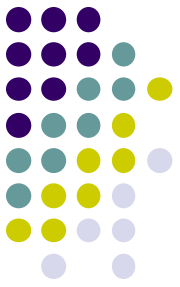

- At the communication destination:
 - R_{clock} shifts each bit received into the Serial In Parallel Out (SIPO) register.
 - After all data bits have been shifted, they are transferred to the received data buffer.
 - The data in the received data buffer can be read by an input operation via the parallel interface.

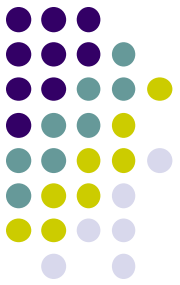

Serial Communication

- There are two basic types of serial communications
 - synchronous
 - asynchronous

Synchronous VS Asynchronous

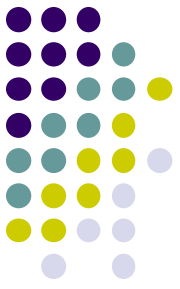

- Synchronous
 - Transmitter and receiver are synchronized
 - Need extra hardware for clock synchronization
 - Having faster data transfer rate
- Asynchronous
 - Transmitter and receiver use different clocks. No clock synchronization is required.
 - Used in many applications such as keyboards, mice, modems
 - The rest of this lecture focuses on Asynchronous communication

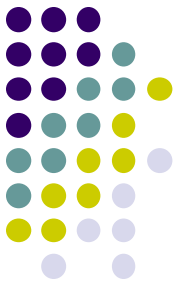

UART

- The device that implements both transmitter and receiver in a single integrated circuit is called a UART (Universal Asynchronous Receiver/Transmitter).
- UART uses least significant first order
 - The least significant bit of data is transferred first
- Data are transmitted asynchronously.
 - Clocks on both sides are not synchronized
 - But receivers have a way to synchronise the data receiving operation with data transmission operation
- UART is the basis for most serial communication hardware.

UART Structure

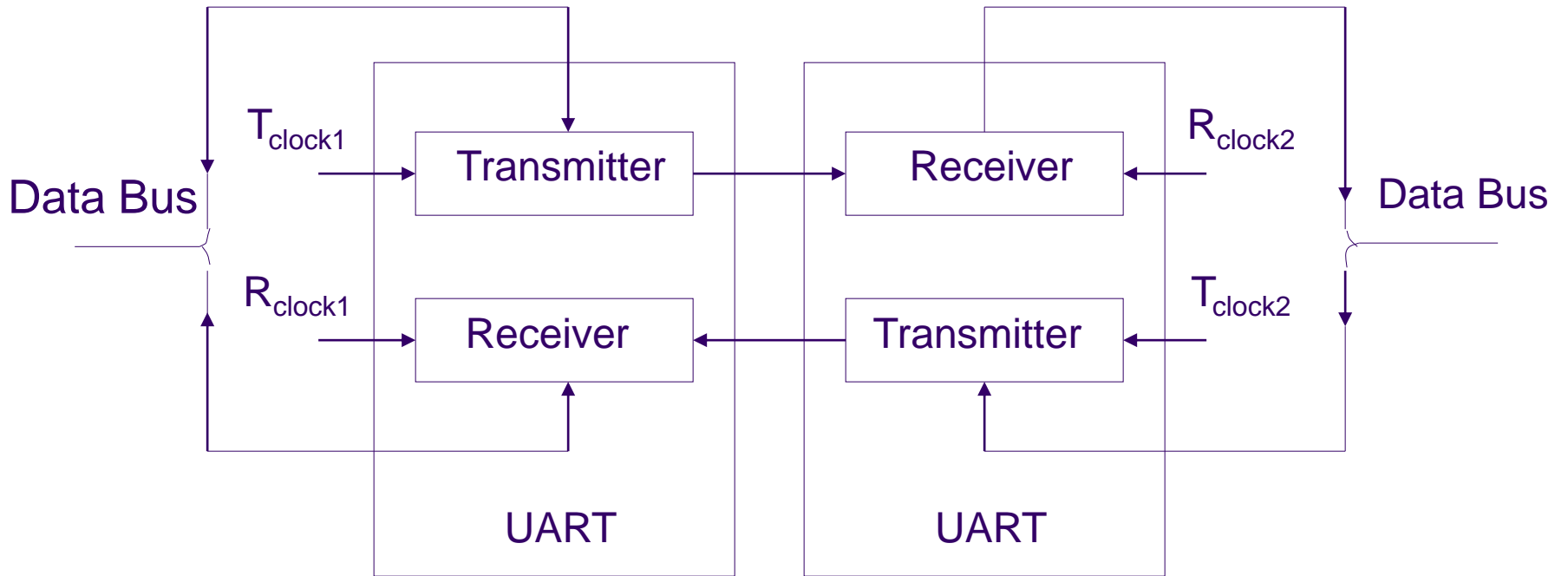
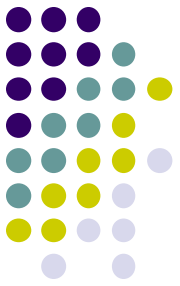

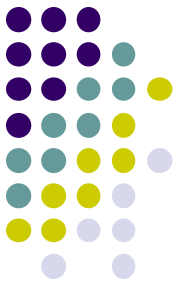

UART Data Formats

- Before transmission, data should be encoded
 - Many encoding schemes, such as ASCII
- Each encoded data is encapsulated with two bits
 - Start bit and stop bit
- **Mark and space**: the logic one and zero levels are called mark and space.
 - When the transmitter is not sending anything, it holds the line at

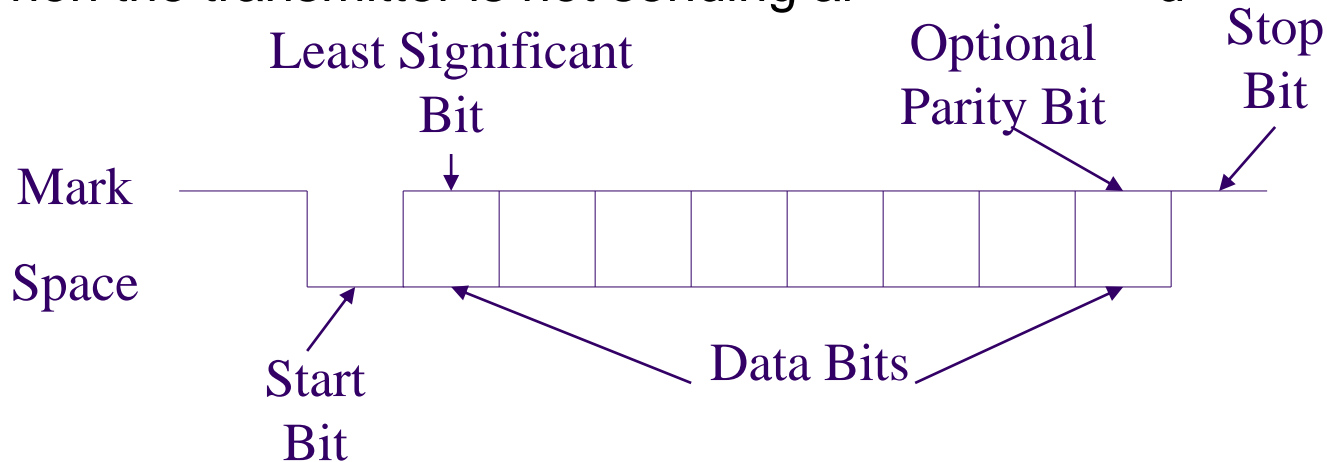

UART Data Formats (cont.)

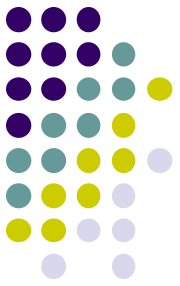

- Typical bits in data transmission:
 - Start bit: When the transmitter has data to send, it first changes the line from the mark to the space level for one bit time. This synchronises the receiver with transmitter. When the receiver detects the start bit, it knows to start clocking in the serial data bits.
 - Data bits: representing a data, such as a character
 - Parity bit: used to detect errors in the data
 - For odd parity: the bit makes the total number of 1s in the data odd
 - For even parity: the bit makes the total number of 1s in the data even.
 - Stop bit: added at the end of data bits. It gives one bit-time between successive data. Some systems require more than one stop bit.

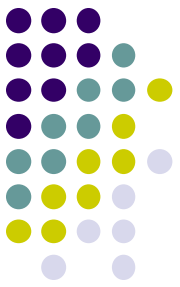

Data Transmission Rate

- The rate at which bits are transmitted is called ***baud rate***.
- It is given in *bits per second*
- Standard data rates – Baud:
110, 150, 300, 600, 900, 1200, 2400, 4800, 9600,
14400, 19200, 38400, 57600, 115200, 230400,
460800, 921600

Communication System Types

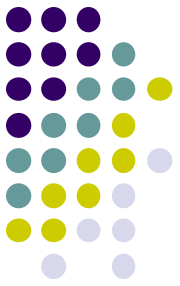

- Three ways that data can be sent in serial communication system:
 - Simplex system
 - Full-duplex (FDX) system
 - Half-duplex (HDX) system

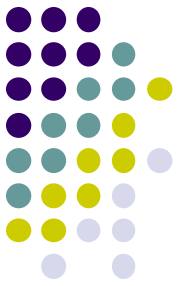

Simplex System

- Data are sent in one direction only
 - For example, computer to a serial printer.
- Simple
 - If the computer does not send data faster than the printer can accept it, no handshaking signals are required.
- Two signal wires are needed for this system.

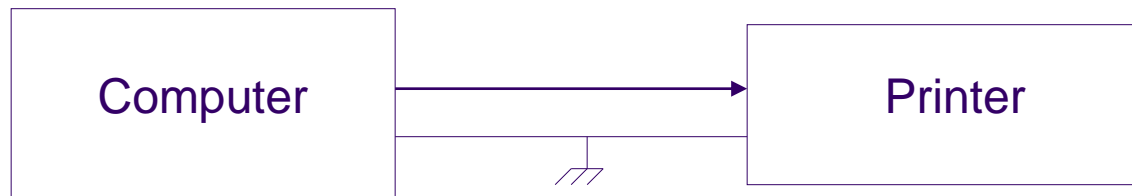

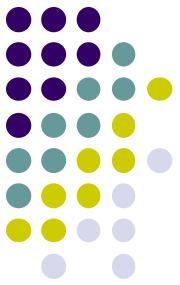

Full-Duplex (FDX) System

- Data are transmitted in two directions.
- It is called four-wire system, although only two signal wires and a common ground are sufficient.

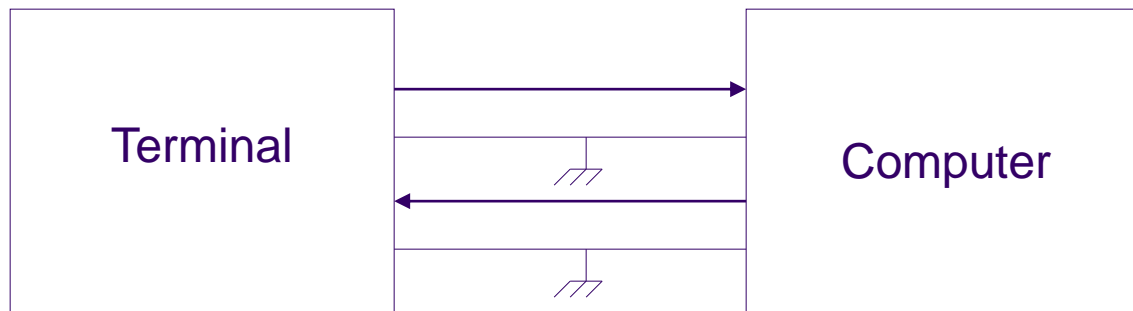

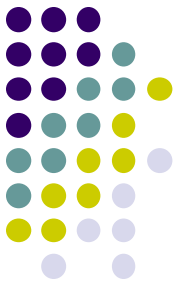

Half-Duplex (HDX) System

- Data are transmitted in two directions with only one pair of signal lines.
- Additional hardware and handshaking signals must be added to an HDX system.

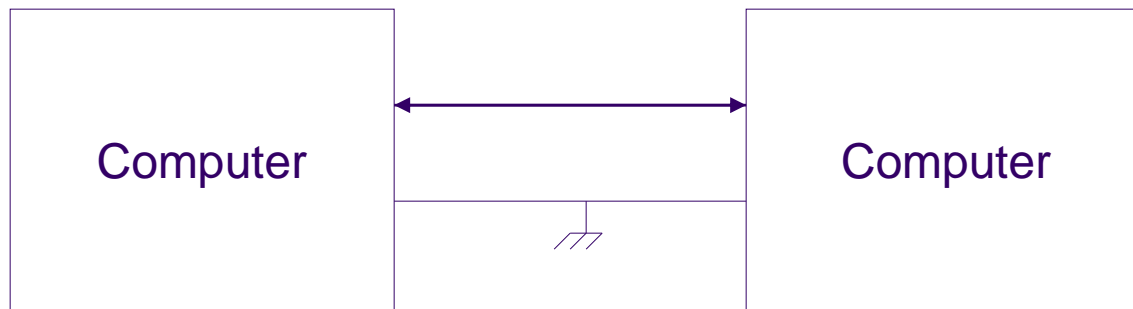

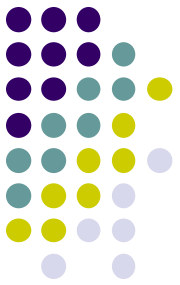

DTE & DCE

- There are two typical devices in communications
- DCE
 - Data Communications Equipment
 - Provides a path for communication
- DTE
 - Data Terminal Equipment
 - Connects to a communication line

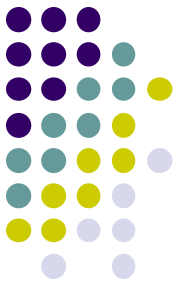

DTE & DCE – example

- A communication system for internet access
 - PC and Internet provider server are DTEs
 - Two modems are DCEs

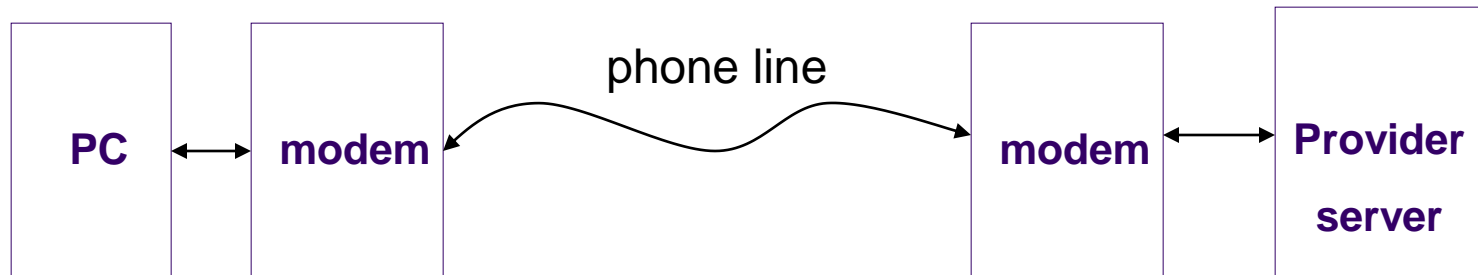

Modem

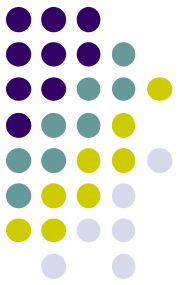

- A modulator/demodulator
 - It converts logic levels into tones to be sent over a telephone line.
 - At the other end of the telephone line, a demodulator converts the tones back to logic levels.

Standards for the Serial I/O Interface

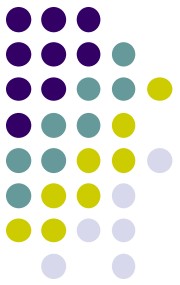

- Interface standards are needed to allow different manufacturers' equipment to be interconnected
- Must define the following elements:
 - Handshaking signals
 - Direction of data flow
 - Types of communication devices.
 - Connectors and interface mechanical considerations.
 - Electrical signal levels.

Standards for the Serial I/O Interface (cont.)



- Popular standards include RS-232-C, RS-422, RS-423 and RS-485.
 - RS-232-C standard is used in most serial interface.
 - If the signals must be transmitted farther than 50 feet or greater than 20 Kbits/second, another electrical interface standard such as RS-422, RS-423 or RS-485 should be chosen.
 - For RS-422, RS-423 and RS-485, handshaking, direction of signal flow, and the types of communication devices are based on the RS-232-C standard.

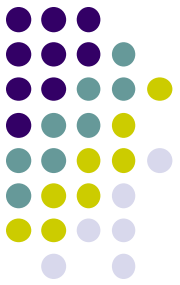

Two RS232-C Connectors

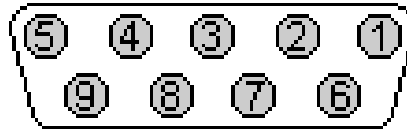

DE9 pin assignments

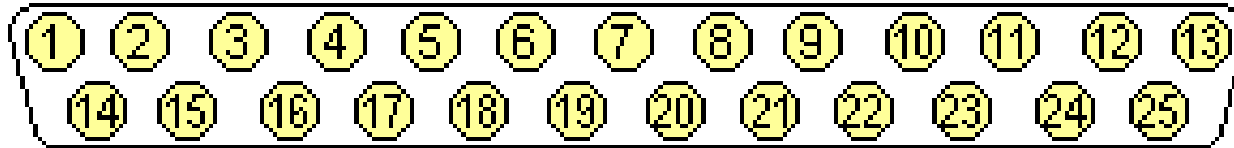

DB25 pin assignments

RS-232-C Signal Definitions

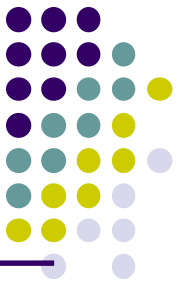

DE9	DB25	Signal	Purpose
	1	PG	Protective ground: this is actually the shield in a shielded cable. It is designed to be connected to the equipment frame and may be connected to external grounds.
3	2	TxD	Transmitted data: Sourced by DTE and received by DCE. Data terminal equipment cannot send unless RTS, CTS, DSR and DTR are asserted.
2	3	RxD	Received data: Received by DTE, sourced by DCE.
7	4	RTS	Request to send: Sourced by DTE, received by DCE. RTS is asserted by the DTE when it wants to send data. The DCE responds by asserting CTS.

RS-232-C Signal Definitions (cont.)

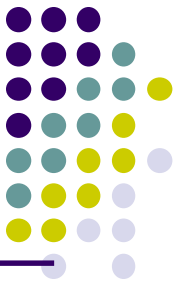

DE9	DB25	Signal	Purpose
8	5	CTS	Clear to send: Sourced by DCE, received by DTE. CTS must be asserted before the DTE can transmit data.
6	6	DSR	Data set ready: Sourced by DCE and received by DTE. Indicates that the DCE has made a connection on the telephone line and is ready to receive data from the terminal. The DTE must see this asserted before it can transmit data.
5	7	SG	Signal ground: Ground reference for this signal is separate from pin 1, protective ground.

RS-232-C Signal Definitions (cont.)

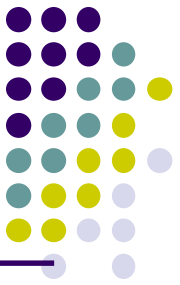

DE9	DB25	Signal	Purpose
1	8	DCD	Data carrier detect: Sourced by DCE, received by DTE. Indicates that a DCE has detected the carrier on the telephone line. Originally it was used in half-duplex systems but can be used in full-duplex systems, too.
4	20	DTR	Data terminal ready: Sourced by DTE and received by DCE. Indicates that DTE is ready to send or receive data.
9	22	RI	Ring indicator: Sourced by DCE and received by DTE. Indicates that a ringing signal is detected.

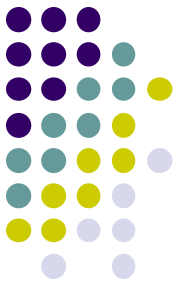

RS-232-C Interconnections

- *When two serial ports are connected, the data rate, the number of data bits, whether parity is used, the type of parity, and the number of stop bits must be set properly and identically on each UART.*
- Proper cables must be used. There are four kinds of cables from which to choose, depending on the types of devices to be interconnected.
 - Full DTE – DCE cable
 - Minimal DTE – DCE cable
 - DTE – DTE null modem cable
 - Minimal null modem cable

RS-232-C Interconnections (cont.)

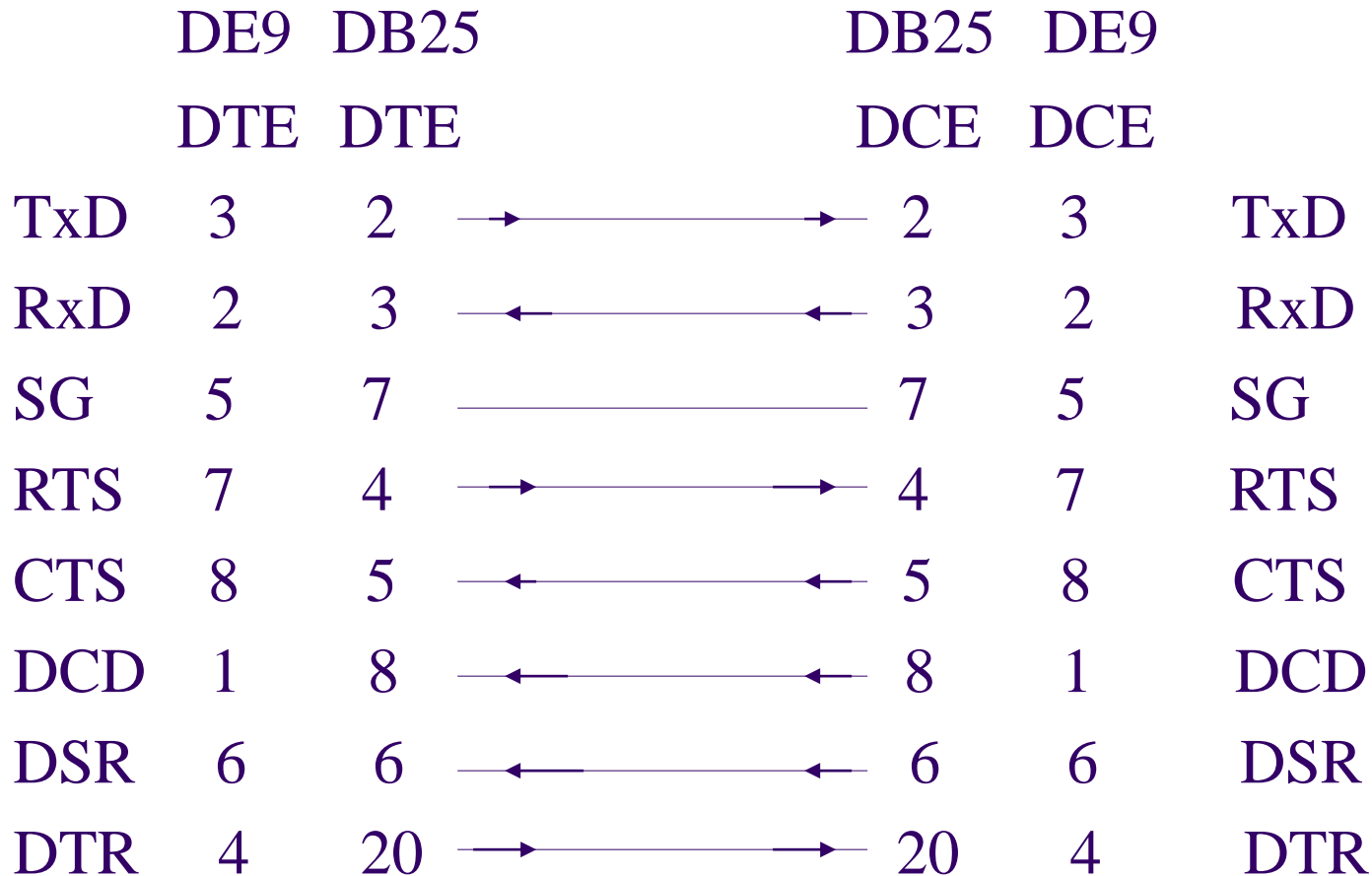
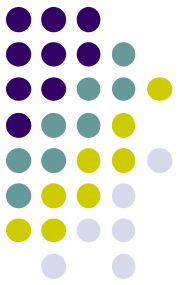

Full DTE – DCE cable

RS-232-C Interconnections (cont.)

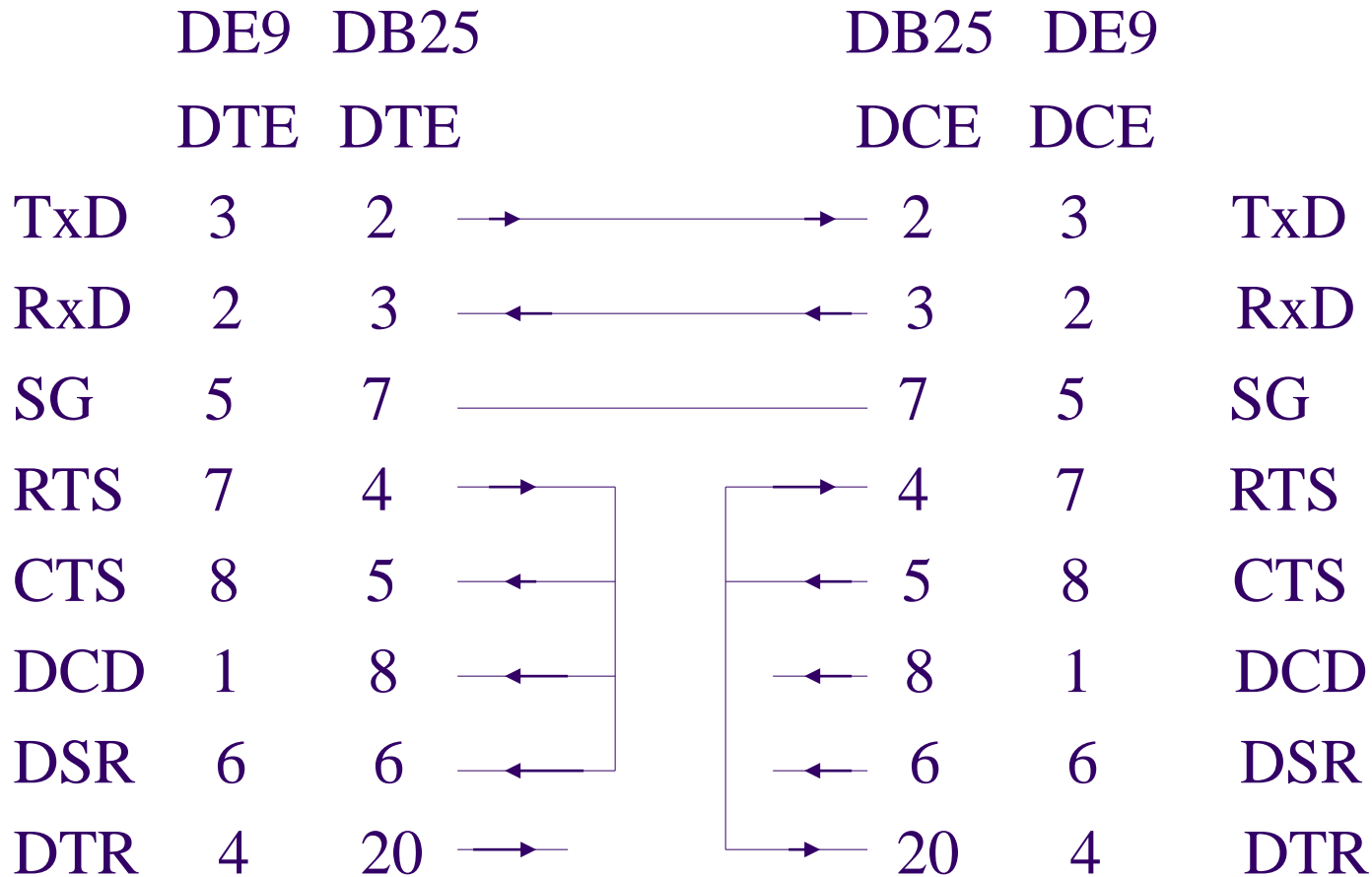
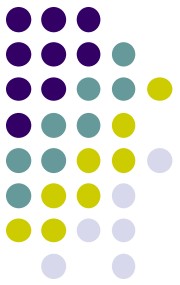

Minimal DTE-DCE cable

RS-232-C Interconnections (cont.)

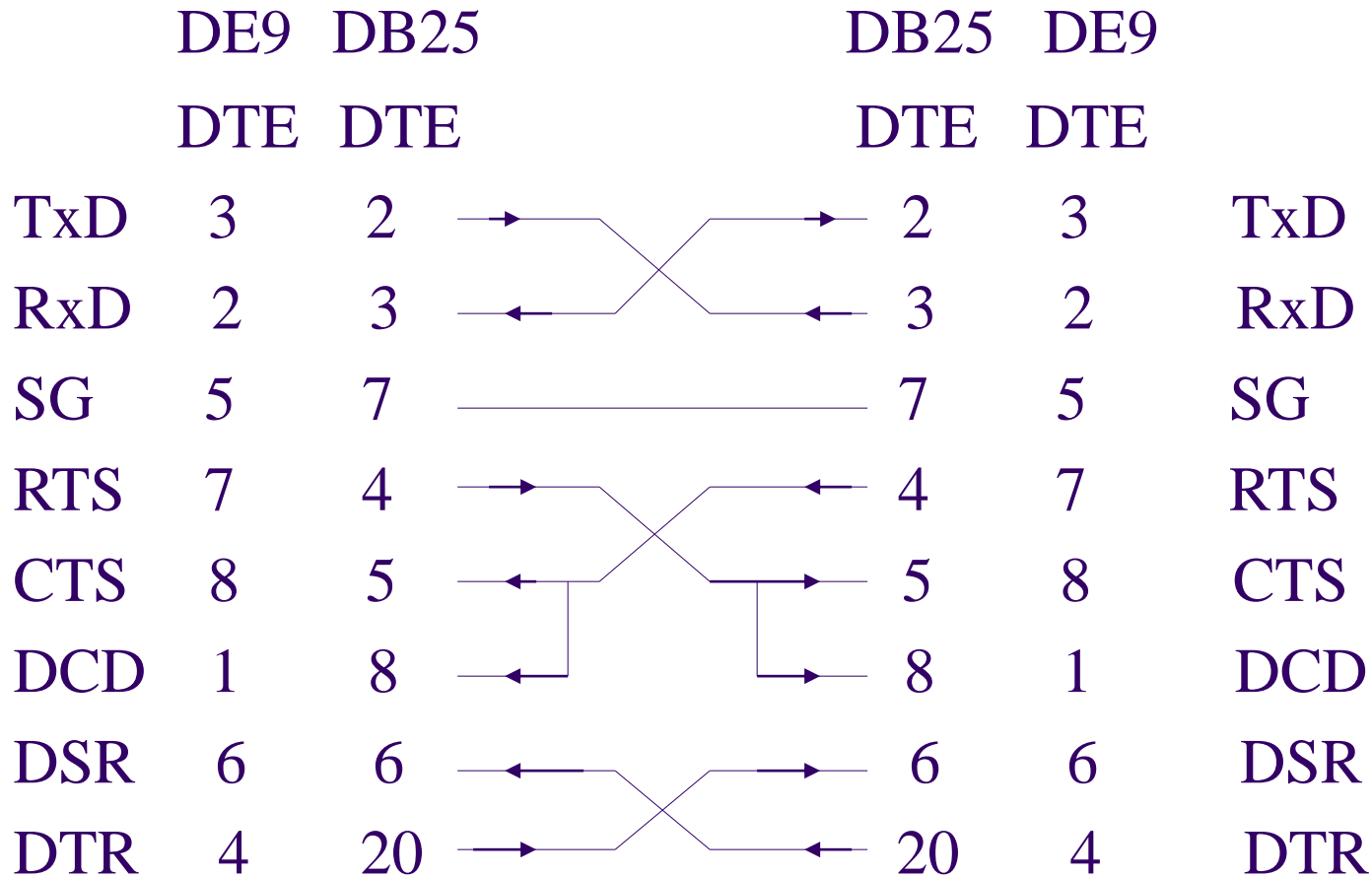
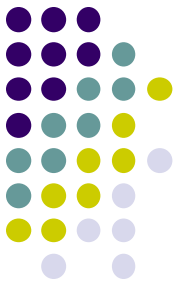

DTE – DTE null modem cable

RS-232-C Interconnections (cont.)

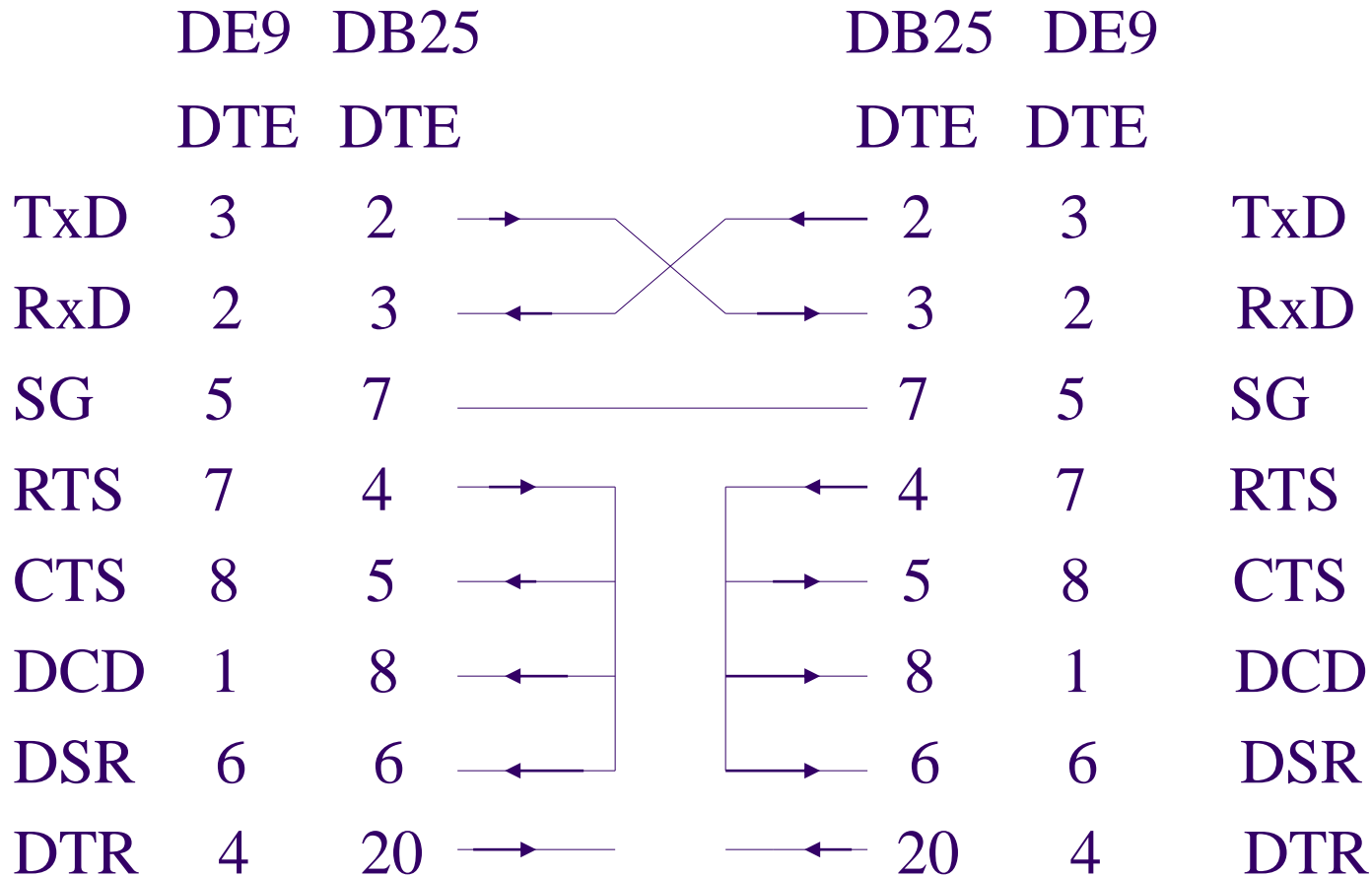
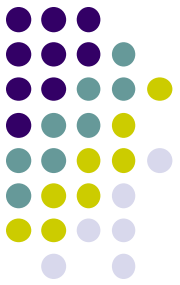

Minimal null modem cable

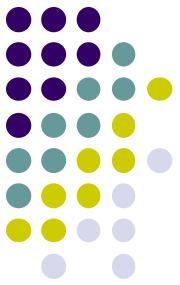

RS-232-C Interface

RS-232-C Logic levels:

Mark -25 to -3 volts

Space +25 to +3 volts

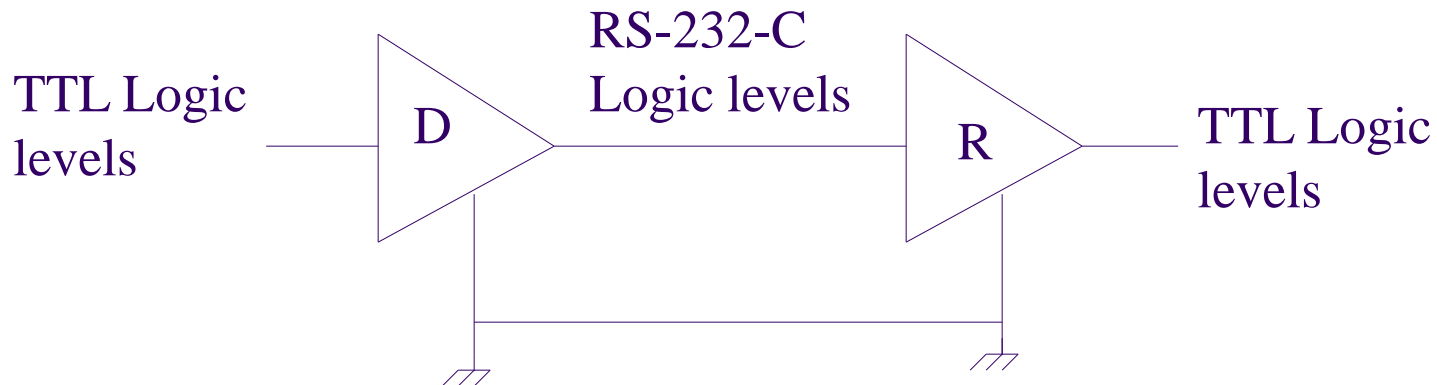

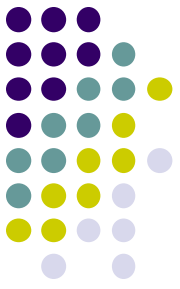

RS-423 Standard

- Also a single ended system.
- Allows longer distance and higher data rates than RS-232-C.
- Allows a driver to broadcast data to 10 receivers.

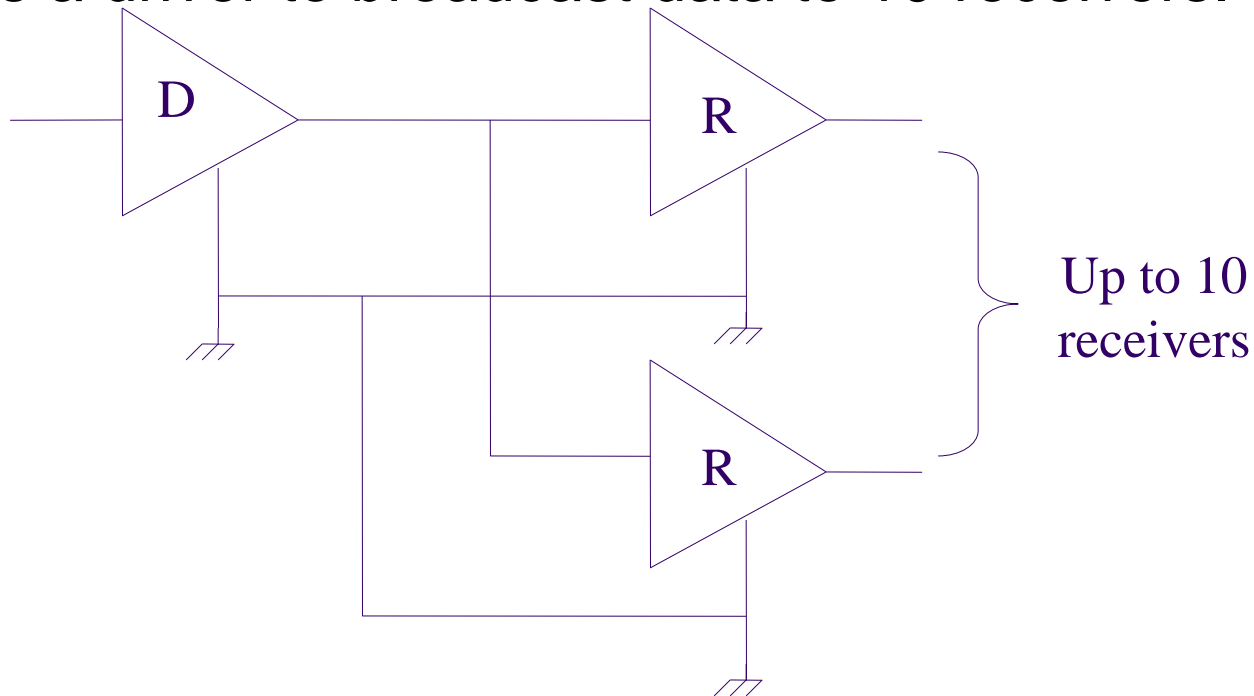

RS-423 Interface

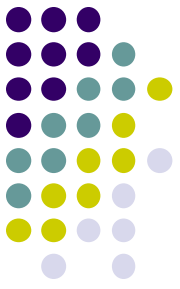

RS-422 Standard

- RS-422 line drivers and receivers operates with differential amplifier.
- These drivers eliminate much of the common-mode noise experienced with long transmission lines, thus allowing the longer distances and higher data rates.

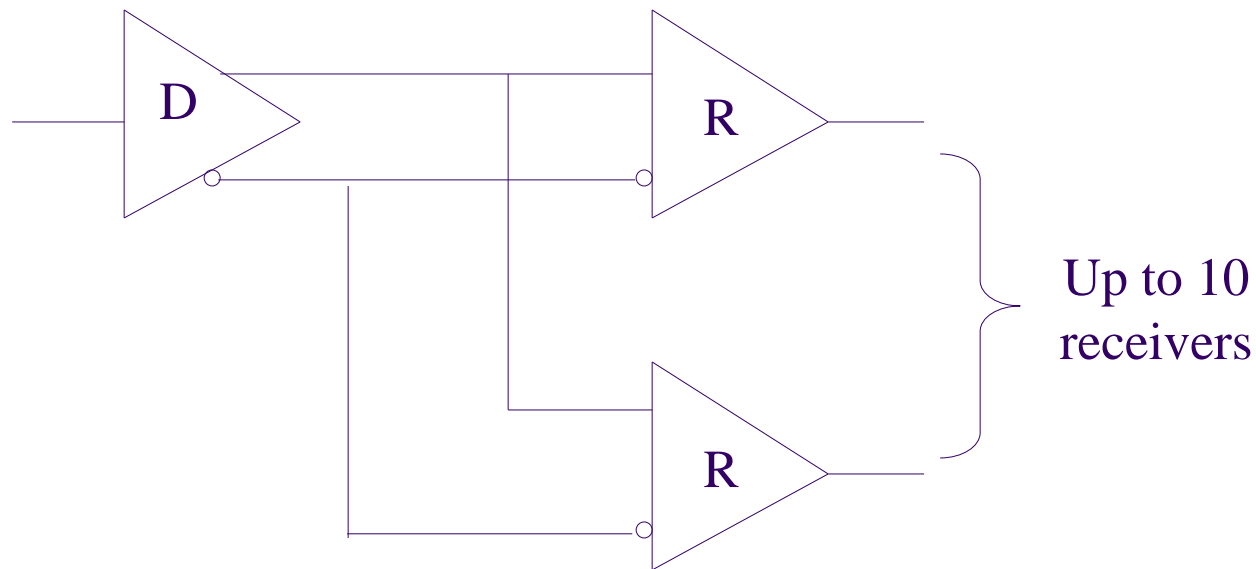

RS-422 Interface



RS-485 Standard

- Similar to RS-422 in that it uses differential line drivers and receivers.
- Unlike RS-422, RS-485 provides for multiple drivers and receivers in a bussed environment.
 - Up to 32 drivers/receivers pairs can be used together.

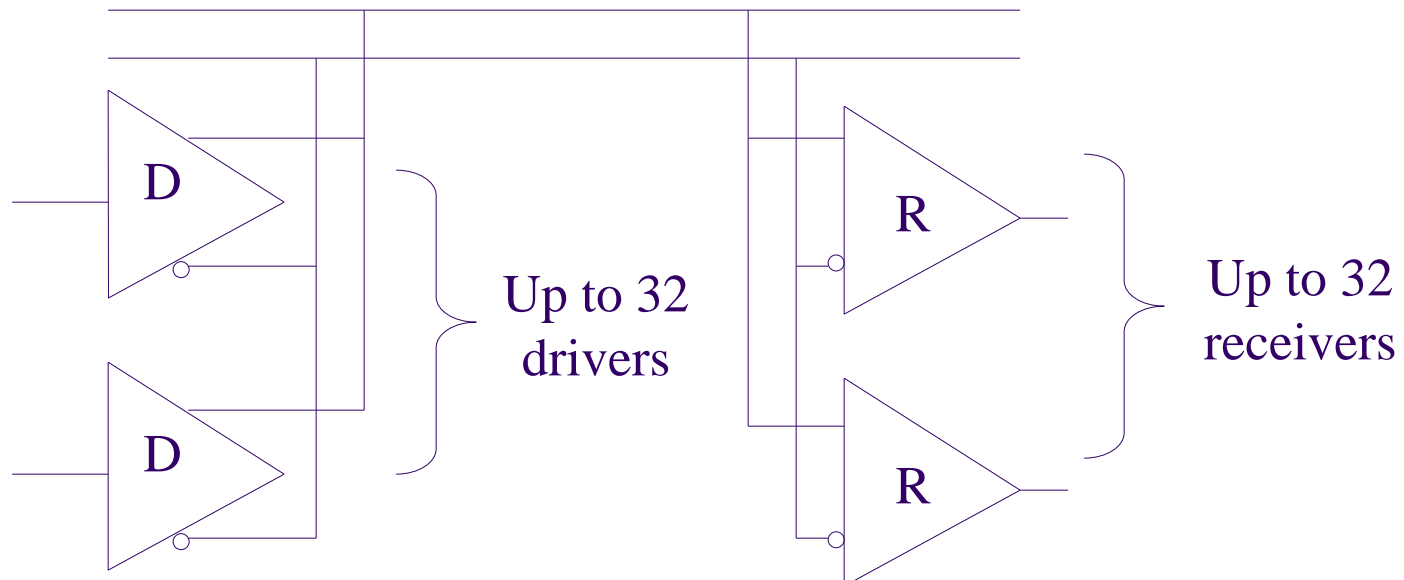

RS-485 Interface

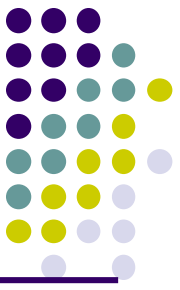

Summary of Standards

Specification	RS-232-C	RS-423	RS-422	RS-485
Receiver input voltage	± 3 to ± 15 V	± 200 mV to ± 12 V	± 200 mV to ± 7 V	± 200 mV to -7 to $+12$ V
Driver output signal	± 5 to ± 15 V	± 3.6 to ± 6 V	± 2 to ± 5 V	± 1.5 to ± 5 V
Maximum data rate	20 Kb/s	100 Kb/s	10 Mb/s	10 Mb/s
Maximum cable length	50 ft	4000 ft	4000 ft	4000 ft
Driver source Impedance	3-7 K Ω	450 Ω min	100 Ω	54 Ω
Receiver input resistance	3 K Ω	4 K Ω min	4 K Ω min	12 K Ω minimum
Mode	Singled-ended	Singled-ended	Differential	Differential
Number of drivers and receivers allowed on one line	1 Driver 1 Receivers	1 driver 10 Receivers	1 Driver 10 Receivers	32 Driver 32 Receivers

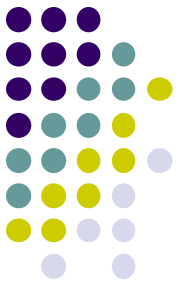

AVR USARTs

- Two USART units
 - Unit 0
 - Unit 1
- Each unit can be configured for synchronous or asynchronous serial communication
- USART unit 0 is used on our lab board to receive program code downloaded from the PC host via USB

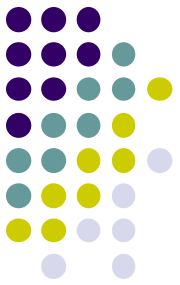

AVR USARTs (cont.)

- Support many serial frames.
- Have transmission error detection
 - Odd or even parity error
 - Framing error
- Three interrupts on
 - TX Complete
 - TX Data Register Empty
 - RX Complete.

USART Block Diagram

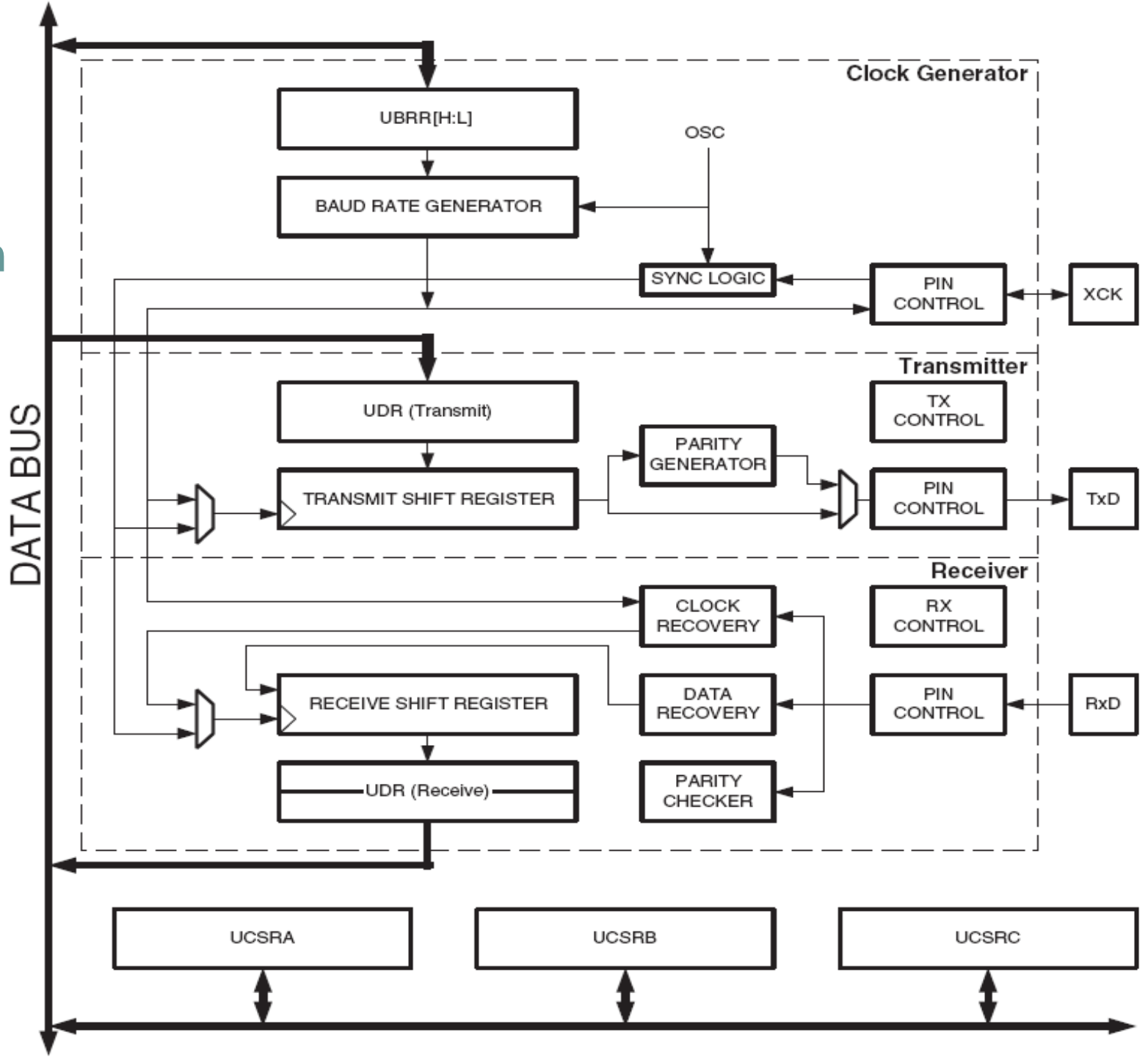

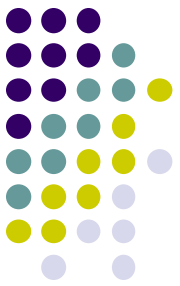

AVR USART Structure

- The USART consists of three components: clock generator, transmitter and receiver
- Clock generator
 - consists of synchronization logic for external clock input used by synchronous slave operation, and the baud rate generator.
- Transmitter
 - consists of a single write buffer, a serial Shift Register, Parity Generator and Control Logic for handling different serial frame formats.

AVR USART Structure (cont.)

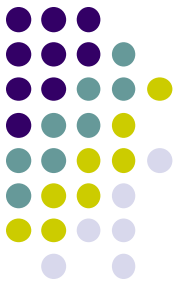

- Receiver
 - The Receiver is the most complex part of the USART module due to its clock and data recovery units.
 - The recovery units are used for asynchronous data reception.
 - In addition to the recovery units, the Receiver includes a Parity Checker, Control Logic, a Shift Register and a Receive Buffer (UDR).
 - The Receiver supports the same frame formats as the Transmitter, and can detect Frame Error, Data Over Run and Parity Error.

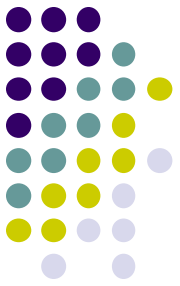

Frame Formats

- Up to 30 formats
 - combinations of
 - 1 start bit (St)
 - 5, 6, 7, 8, or 9 data bits
 - no, even or odd parity bit (P)
 - 1 or 2 stop bits (Sp)
- Example

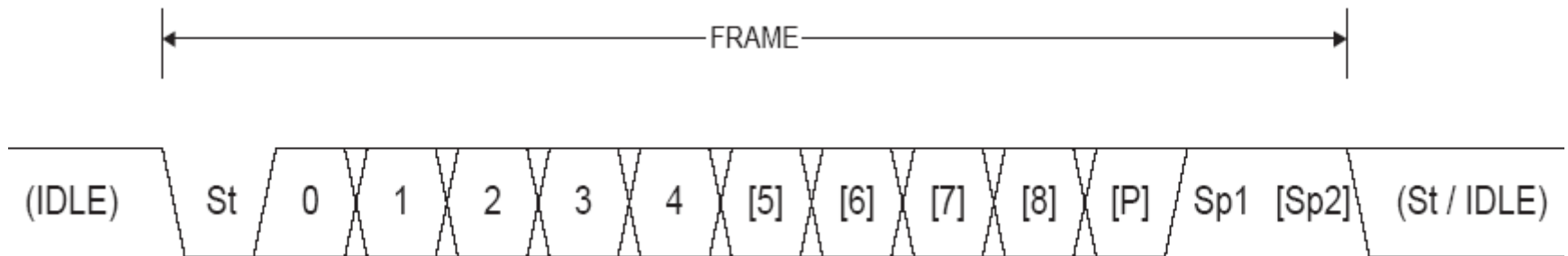



Parity Bit

- Used to check whether the received data is different from the sending data
- Two forms of the parity bit

- Even parity

$$P_{\text{even}} = d_n \oplus d_{n-1} \oplus \dots \oplus d_1 \oplus d_0 \oplus 0$$

- Odd parity

$$P_{\text{odd}} = d_n \oplus d_{n-1} \oplus \dots \oplus d_1 \oplus d_0 \oplus 1$$

- Where d_i in the two formulas is a data bit, n is the number of data bits.

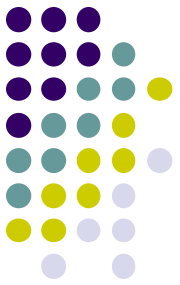

Control Registers

- Three control registers are used in USART operation:
 - UCSRA
 - for storing the status flags of USART
 - for controlling transmission speed and use of multiple processors
 - UCSRB
 - for enabling interrupts, transmission operations
 - for setting frame formats
 - for bit extension
 - UCSRC
 - For operation configuration

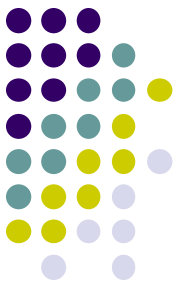

UCSRA

- USART Control and Status Register A

Bit	7	6	5	4	3	2	1	0
	RXC	TXC	UDRE	FE	DOR	UPE	U2X	MPCM
Read/Write	R	R/W	R	R	R	R	R/W	R/W
Initial Value	0	0	1	0	0	0	0	0

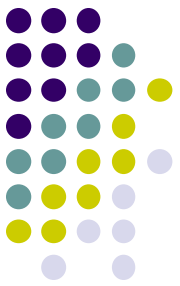

UCSRA Bit Descriptions

- Bit 7 – RXC: USART Receive Complete
 - Set when the receive buffer is not empty
 - The RXC flag can be used to generate a Receive Complete interrupt
- Bit 6 – TXC: USART Transmit Complete
 - Set when the entire frame in the Transmit Shift Register has been shifted out and there are no new data present in the transmit buffer
 - TXC is automatically cleared when a transmit complete interrupt is executed.
 - TXC can generate a Transmit Complete interrupt

UCSRA Bit Descriptions (cont.)

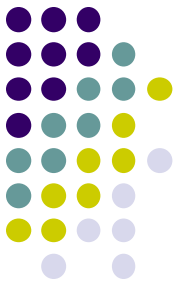

- Bit 5 – UDRE: USART Data Register Empty
 - Set when the transmit buffer (UDR) is empty
 - Can be used to generate a Data Register Empty interrupt
- Bit 4 – FE: Frame Error
 - Set when the next character in the receive buffer had a Frame Error when received.
- Bit 3 – DOR: Data OverRun
 - Set when a Data OverRun condition is detected.
 - A Data OverRun occurs when the receive buffers are all full and a new start bit is detected.

UCSRA Bit Descriptions (cont.)

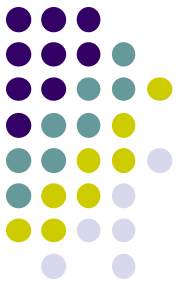

- Bit 2 – UPE: USART Parity Error
 - Set when the next character in the receive buffer had a Parity Error when received and the Parity Checking was enabled
- Bit 1 – U2X: Double the USART Transmission Speed
 - Set for doubling the transfer rate for asynchronous communication
- Bit 0 – MPCM: Multi-processor Communication Mode
 - If set, all the incoming frames received by the USART Receiver that do not contain address information will be ignored.

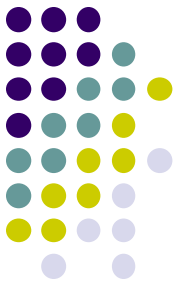

UCSRB

- USART Control and Status Register B

Bit	7	6	5	4	3	2	1	0
	RXCIE	TXCIE	UDRIE	RXEN	TXEN	UCSZ2	RXB8	TXB8
Read/Write	R/W	R/W	R/W	R/W	R/W	R/W	R	R/W
Initial Value	0	0	0	0	0	0	0	0

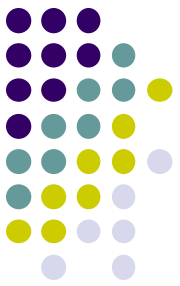

UCSRB Bit Descriptions

- Bit 7 – RXCIE: RX Complete Interrupt Enable
 - Set to enable interrupt on the RXC flag
- Bit 6 – TXCIE: TX Complete Interrupt Enable
 - Set to enable interrupt on the TXC flag
- Bit 5 – UDRIE: USART Data Register Empty Interrupt Enable
 - Set to enable interrupt on the UDRE flag.

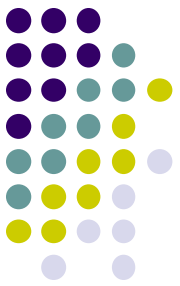

UCSRB Bit Descriptions (cont.)

- Bit 4 – RXEN: Receiver Enable
 - Set the enable the USART receiver.
 - The Receiver will override normal port operation for the RxD pin when enabled. Disable the Receiver will flush the receive buffer invalidating the FE, DOR and UPE flags.
- Bit 3 – TXEN: Transmitter Enable
 - Set to enable the USART Transmitter
 - The Transmitter will override normal port operations for the TxD pin when enabled. The disabling of the Transmitter will not become effective until transmissions are complete.

UCSRB Bit Descriptions (cont.)

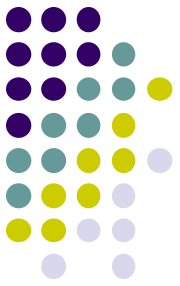

- Bit 2 – UCSZ2: Character Size
 - The bit combined with the UCSZ1:0 bits in UCSRC sets the number of data bits in a frame.
- Bit 1 – RXB8: Receive Data Bit 8
 - The ninth data bit of the received character when operating with serial frames with nine data bits. Must be read before reading the low bits from UDR
- Bit 0 – TXB8: Transmit Data Bit 8
 - The ninth data bit in the character to be transmitted when operating with serial frames with nine data bits. Must be written before writing the low bits to UDR

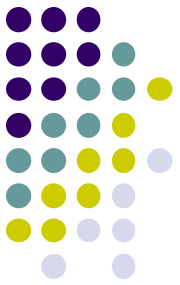

UCSRC

- USART Control and Status Register C

Bit	7	6	5	4	3	2	1	0
	–	UMSEL	UPM1	UPM0	USBS	UCSZ1	UCSZ0	UCPOL
Read/Write	R/W	R/W	R/W	R/W	R/W	R/W	R/W	R/W
Initial Value	0	0	0	0	0	1	1	0

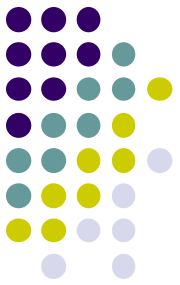

UCSRC Bit Descriptions

- Bit 6 – UMSEL: USART Mode Select
 - 0: Asynchronous Operation
 - 1: Synchronous Operation
- Bit 5:4 – UPM1:0: Parity Mode
 - Set to enable Parity bit operation

UPM1	UPM0	Parity Mode
0	0	Disabled
0	1	Reserved
1	0	Enabled, Even Parity
1	1	Enabled, Odd Parity



UCSRC Bit Descriptions (cont.)

- Bit 3 – USBS: Stop Bit Select
 - 0: 1-bit
 - 1: 2-bit
- Bit 2:1 – UCSZ1:0: Character Size
 - Together with UCSZ2 to determine the number of bits for a character

UCSZ2	UCSZ1	UCSZ0	Character Size
0	0	0	5-bit
0	0	1	6-bit
0	1	0	7-bit
0	1	1	8-bit
1	0	0	Reserved
1	0	1	Reserved
1	1	0	Reserved
1	1	1	9-bit

UCSRC Bit Descriptions (cont.)

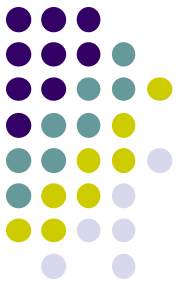

- Bit 0 – UCPCOL: Clock Polarity

UCPOL Sampled	Transmitted Data Changed (Output of TxD Pin)	Received Data (Input on RxD Pin)
0	Rising XCK Edge	Falling XCK Edge
1	Falling XCK Edge	Rising XCK Edge

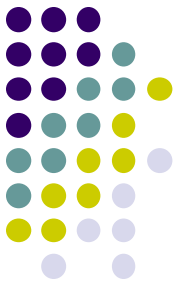

USART Initialization

- Initialization process consists of
 - Setting the baud rate,
 - Setting the frame format; and
 - Enabling the Transmitter or the Receiver
- For interrupt driven USART operation, the Global Interrupt Flag should be cleared when doing the initialization

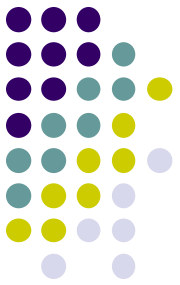

Sample Code

- Initialize USART 1

```
USART_Init:
    ; Set baud rate, which is stored in r17:r16
    sts UBRR1H, r17
    sts UBRR1L, r16

    ; Enable receiver and transmitter
    ldi r16, (1<<RXEN1)|(1<<TXEN1)
    sts UCSR1B,r16

    ; Set frame format: 8 bit data, 2 stop bits
    ldi r16, (1<<USBS1)|(3<<UCSZ10)
    sts UCSR1C,r16
```

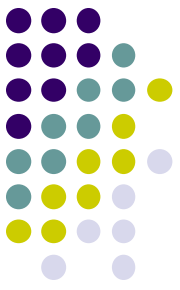

Data Transmission

- The USART Transmitter is enabled by setting the *Transmit Enable* (TXEN) bit in the UCSRB Register.
 - A data transmission is initiated by loading the transmit buffer with the data to be transmitted.
 - The CPU can load the transmit buffer by writing to the UDR I/O location. The buffered data in the transmit buffer will be moved to the Shift Register when the Shift Register is ready to send a new frame.
 - The Shift Register is loaded with new data if it is in idle state (no ongoing transmission) or immediately after the last stop bit of the previous frame is transmitted. When the Shift Register is loaded with new data, it will transfer one complete frame at the rate given by the baud register, $U2X_{59}$ bit or by XCK depending on mode of operation.

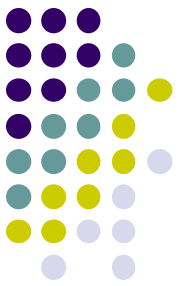

Sample code

- Data Transmission

- The code below uses polling of the *Data Register Empty* (UDRE) flag.
- When using frames with less than eight bits, the most significant bits written to the UDR are ignored.

```
USART_Transmit:
```

```
    ; Wait for empty transmit buffer
```

```
    lds r15, UCSR1A
```

```
    sbrs r15,UDRE1
```

```
    rjmp USART_Transmit
```

```
    ; Put data (r16) into buffer, sends the data
```

```
    sts UDR1,r16
```

Status of Data Transmission

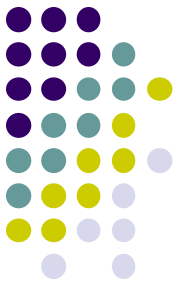

- The USART Transmitter has two flags that indicate its state:
 - USART Data Register Empty (UDRE)
 - Set: when the transmit buffer is empty and ready to receive new data
 - Clear: when the transmit buffer contains data to be moved into the shift register
 - Transmit Complete (TXC)
 - Set: when data in the Transmit Shift Register has been shifted out and there are no new data currently present in the transmit buffer
 - Clear: otherwise
- Both flags can be used for generating interrupts.

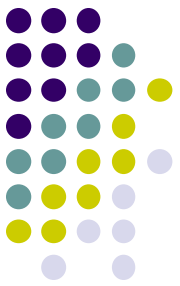

Data Reception

- The USART Receiver is enabled by writing the Receive Enable (RXEN) bit in the UCSRB Register
 - The baud rate, mode of operation and frame format must be set up once before doing any transmissions. If synchronous operation is used, the clock on the XCK pin will be overridden and used as transmission clock.

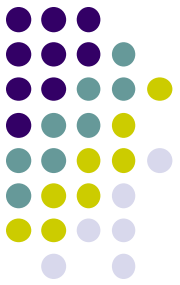

Sample code

- Data reception

```
USART_Receive:
```

```
    ; Wait for data to be received
```

```
    lds    r10, UCSR1A
```

```
    sbrs  r10, RXC1
```

```
    rjmp  USART_Receive
```

```
    ; Get and return received data from buffer
```

```
    lds    r16, UDR1
```

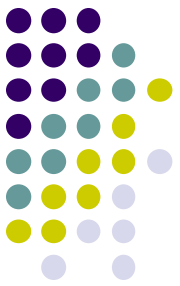

Status of Data Reception

- The Receive Complete (RXC) flag indicates if there are unread data present in the receive buffer.
 - Set: when unread data exist in the receive buffer
 - Clear: otherwise
- If the receiver is disabled ($RXEN = 0$), the receive buffer will be flushed and consequently the RXC bit will become zero.

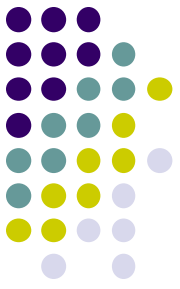

Error Detection

- Three errors are checked on the receiver side:
 - Frame error
 - By checking whether the first stop bit is correctly received
 - Parity error
 - By checking whether the data received has the same (odd or even) number of 1's as in the data from the transmitter.
 - Data OverRun error
 - By checking if any data is yet read but is overwritten by incoming data frame.

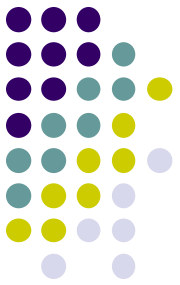

Error Recovery

- Main sources of errors in asynchronous data transmission
 - Data reception is “out sync” with transmission
 - Noise added to the data

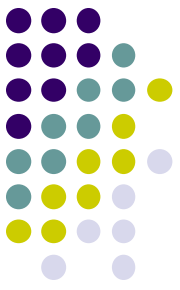

Error Recovery (cont.)

- AVR includes a clock recovery and a data recovery unit for handling errors in asynchronous transmission.
 - The clock recovery logic is used for synchronizing the internally generated baud rate clock to the incoming asynchronous serial frames at the RxD pin.
 - Based on the start bit
 - The data recovery logic samples and low pass filters each incoming bit, thereby improving the noise immunity of the Receiver
 - Based on multiple sampling and majority policy for each incoming bit

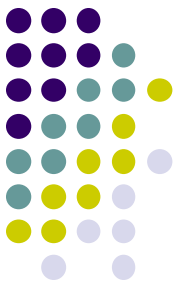

Error Recovery (cont.)

- The following figure gives an illustration
 - The sample rate is 16 times the baud rate
 - When the Clock Recovery logic detects a high (idle) to low (start) transition on the RxD line, it uses the samples 8, 9 and 10 to decide if it is a valid bit (namely, 0)
 - If the majority of the three bits are 0, the bit is valid; data recovery is followed.
 - If the majority of the three bits are 1, the bit is invalid; the circuit looks for next start bit.

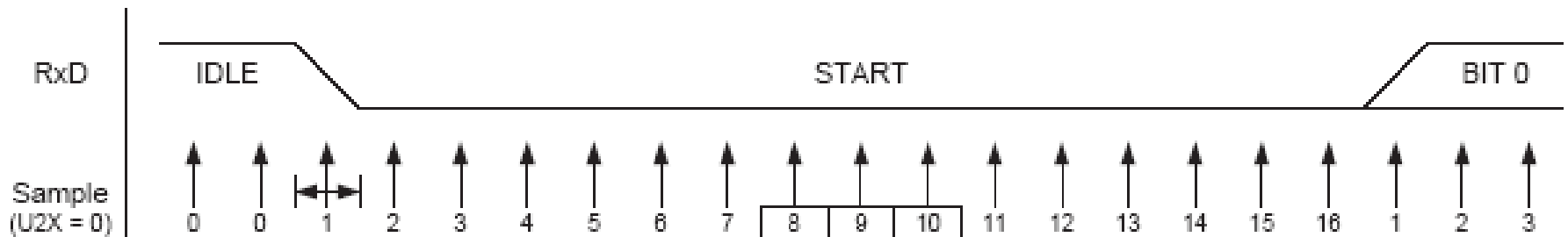

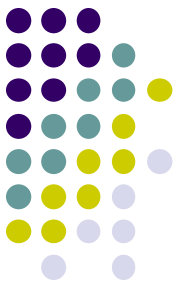

Error Recovery (cont.)

- When the receiver clock is synchronized to the start bit, the data recovery can begin for each subsequent data bit.
- The decision of the logic level of the received bit is taken by doing a majority voting of the logic value to the three samples in the center of the

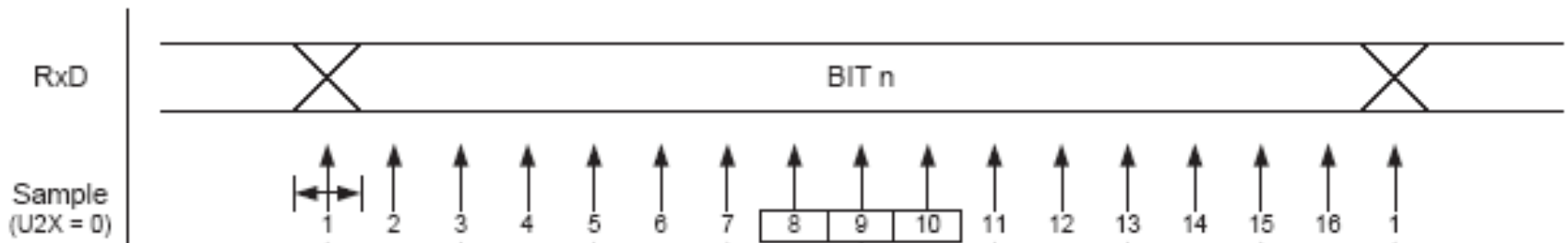

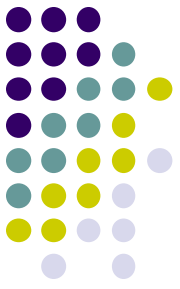

Reading Material

- Chapter 7: Computer Buses and Parallel Input and Output. Microcontrollers and Microcomputers by Fredrick M. Cady.
- Mega2560 Data Sheet
 - USART