

DESN2000
(Computer
Engineering)
2026 T2

Timers

Hasindu Gamaarachchi

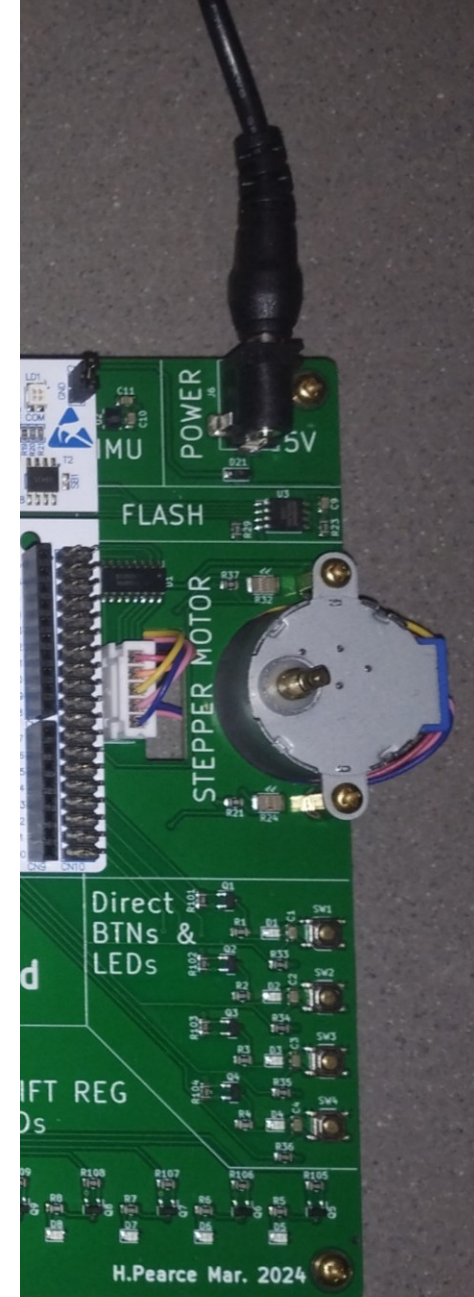

- Theory covered on the whiteboard
- Example coding on STM32 cubeIDE

General Purpose Timers

- Different modes
 - Timer mode (time-base generator)
 - Generate a delay
 - Counter mode
 - Count external events (through an external timer input pin)
 - Input capture
 - Measure the duration between two events
 - Output compare
 - Indicates when the timer value matches the compare register value (e.g., assigned on an output pin)
 - PWM - discussed in week 7, Monday lecture
 - Control an analogue variable

Input Capture Mode

- Capture the timestamp of the occurrence of a rising or a falling edge transition in a digital signal

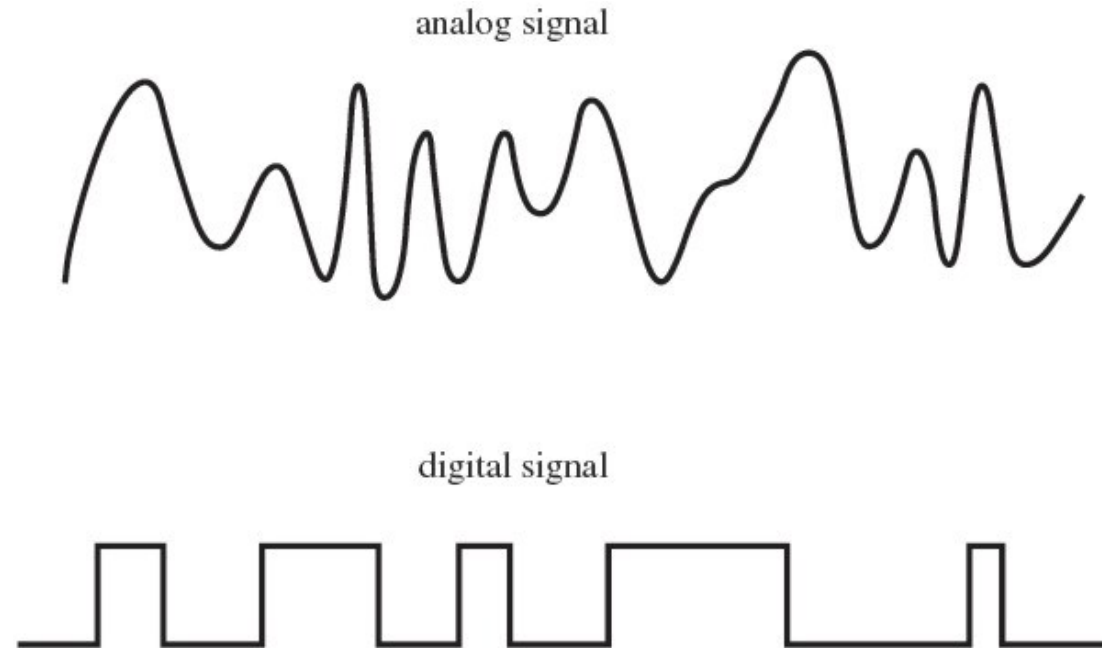

Input Capture

Figure adapted from: Yifeng Zhu, Embedded Systems with ARM Cortex-M Microcontrollers in Assembly Language and C

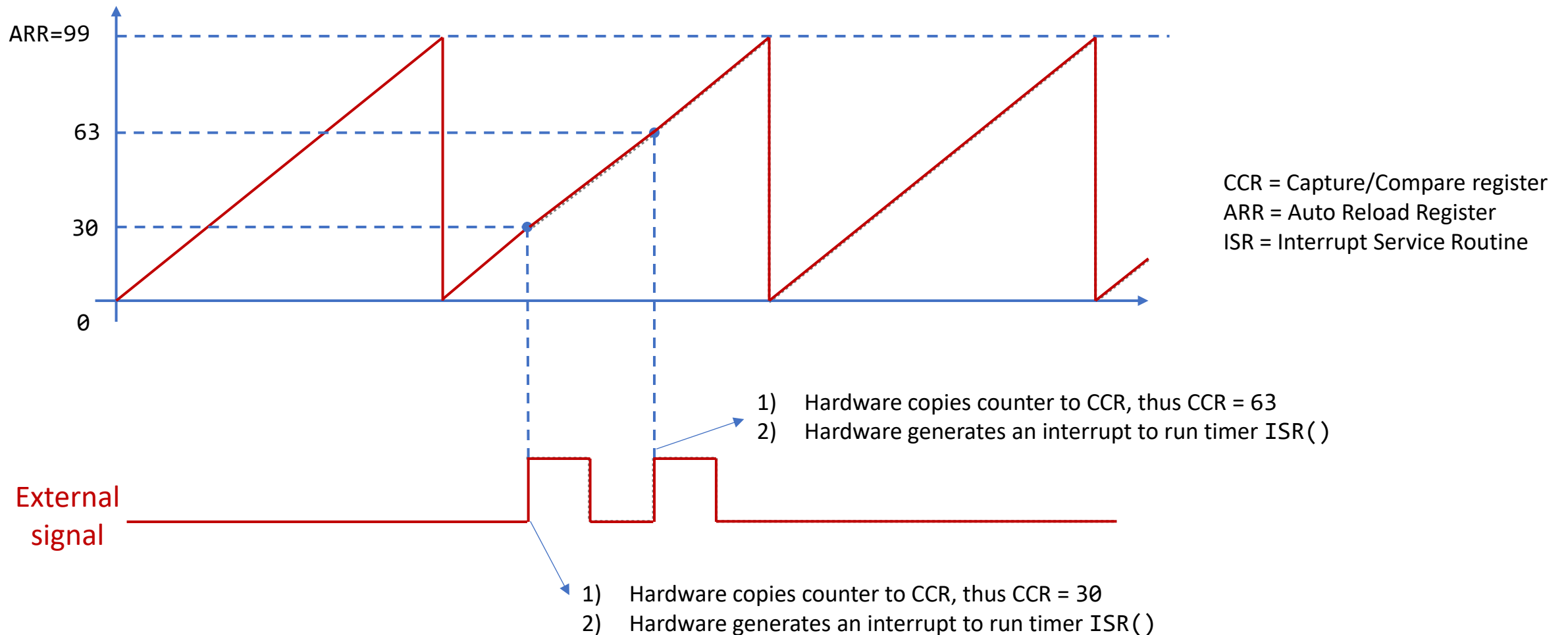

Time span between two events = $63 - 30 = 33$ time units

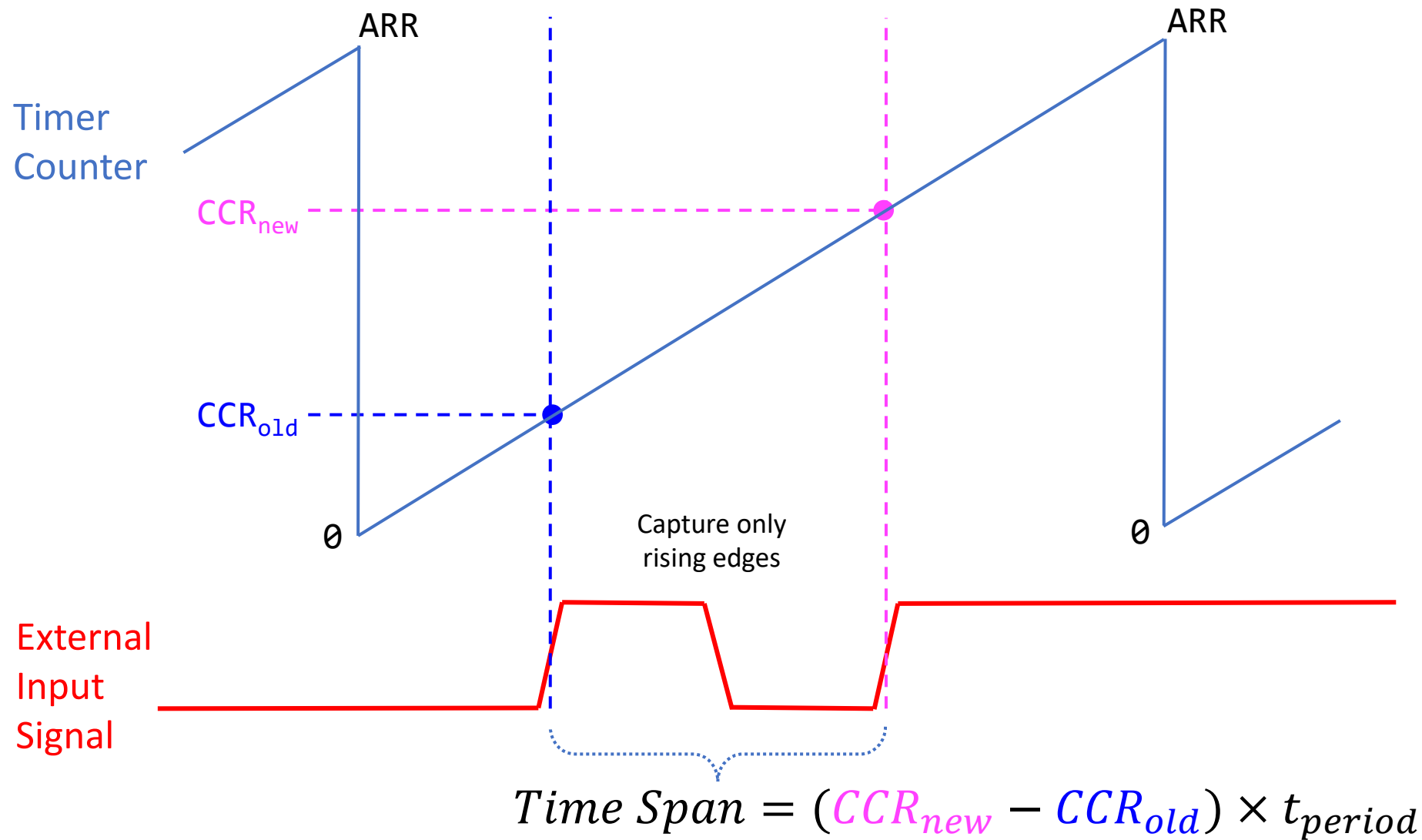

$$t_{period} = \frac{(ARR + 1)(PSC + 1)}{f_{clk}}$$

Input Capture

Figure from: Yifeng Zhu, Embedded Systems with ARM Cortex-M Microcontrollers in Assembly Language and C

- Record the timestamp of an external event
- Capture both rising and falling edges

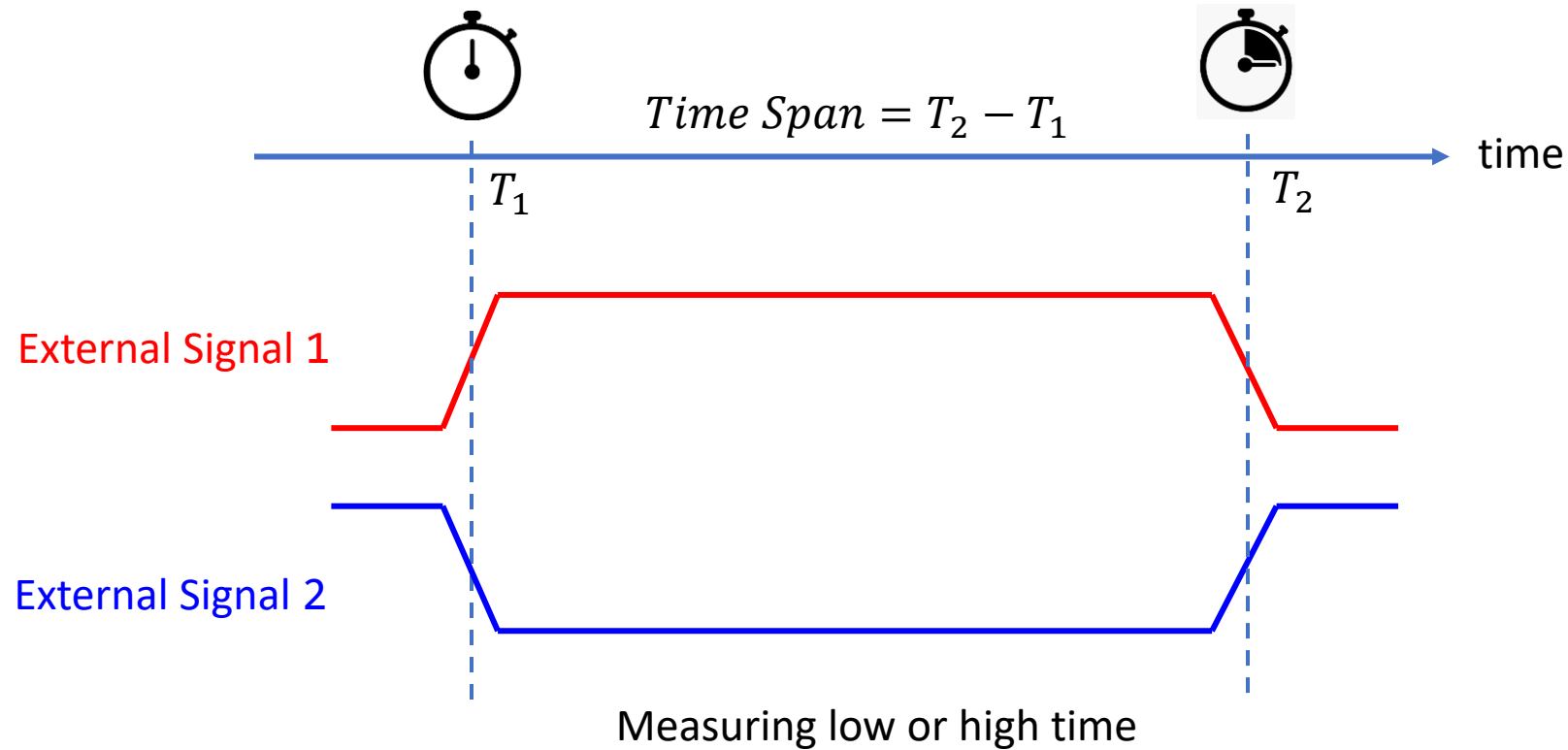

Input Capture

Figure adapted from: Yifeng Zhu, Embedded Systems with ARM Cortex-M Microcontrollers in Assembly Language and C

- Capture only rising edges or only falling edges

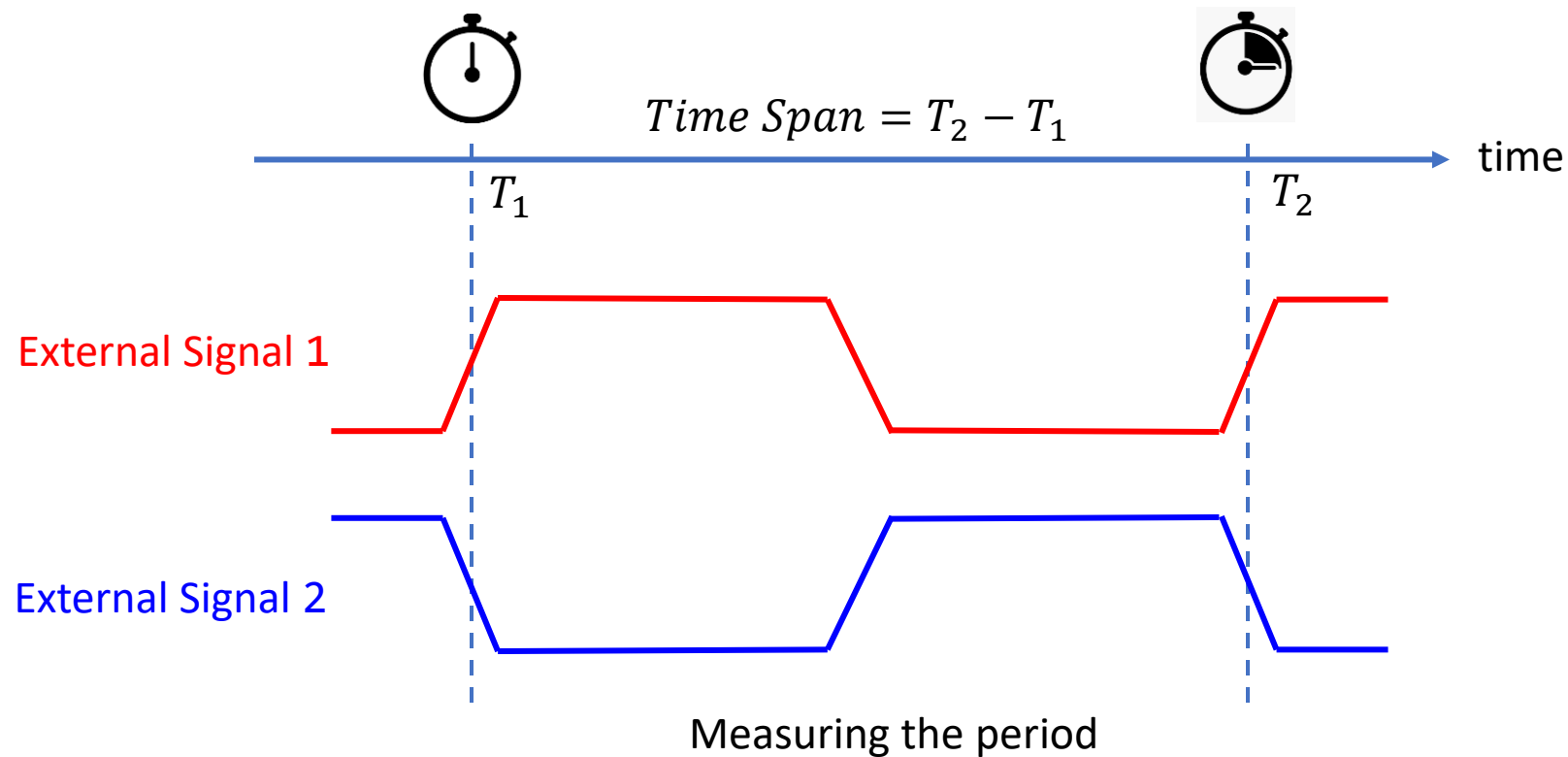

Timer: Input Capture

Figure from: Yifeng Zhu, Embedded Systems with ARM Cortex-M Microcontrollers in Assembly Language and C

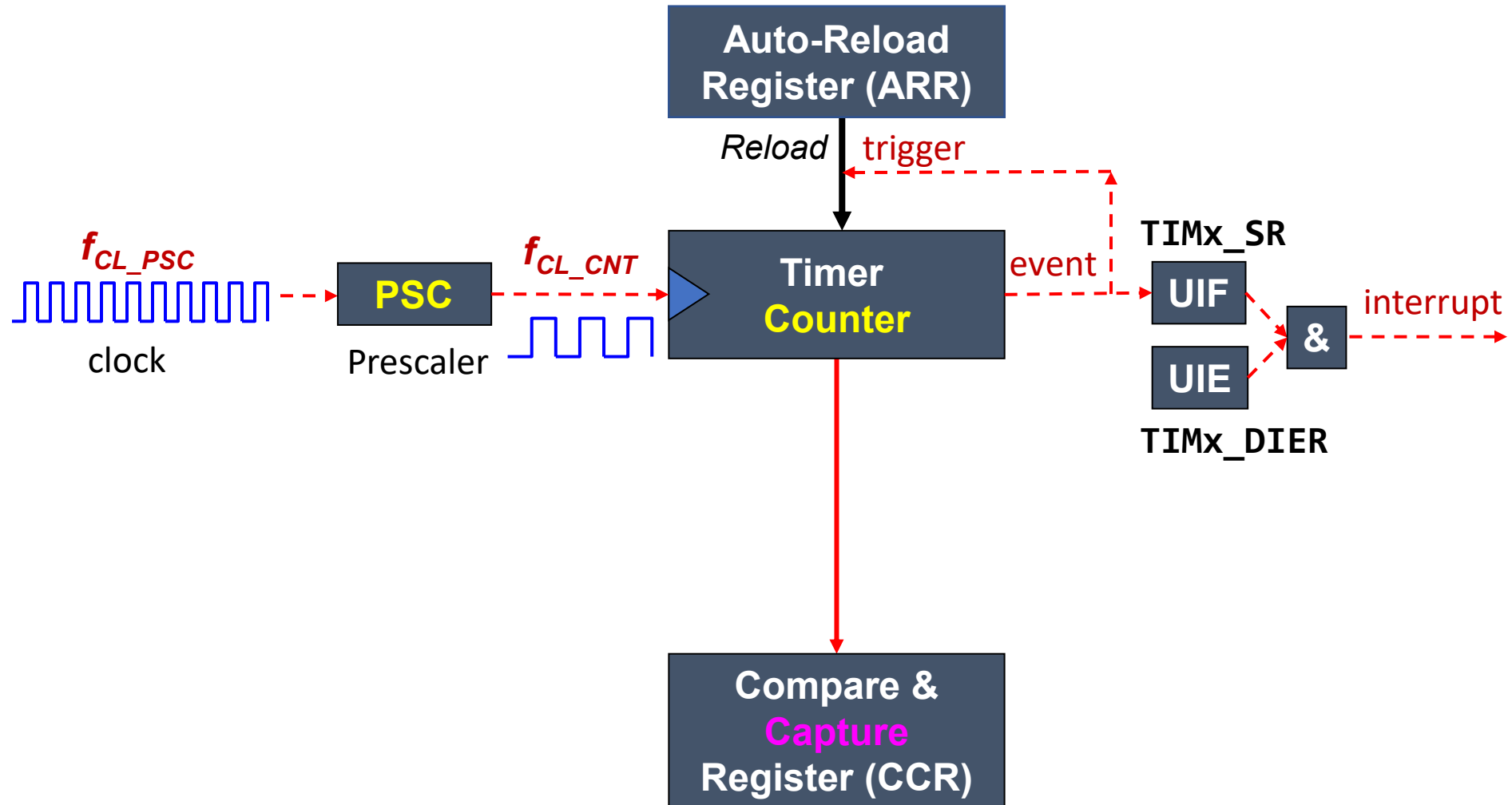

Input Capture Diagram

Figure from: Yifeng Zhu, Embedded Systems with ARM Cortex-M Microcontrollers in Assembly Language and C

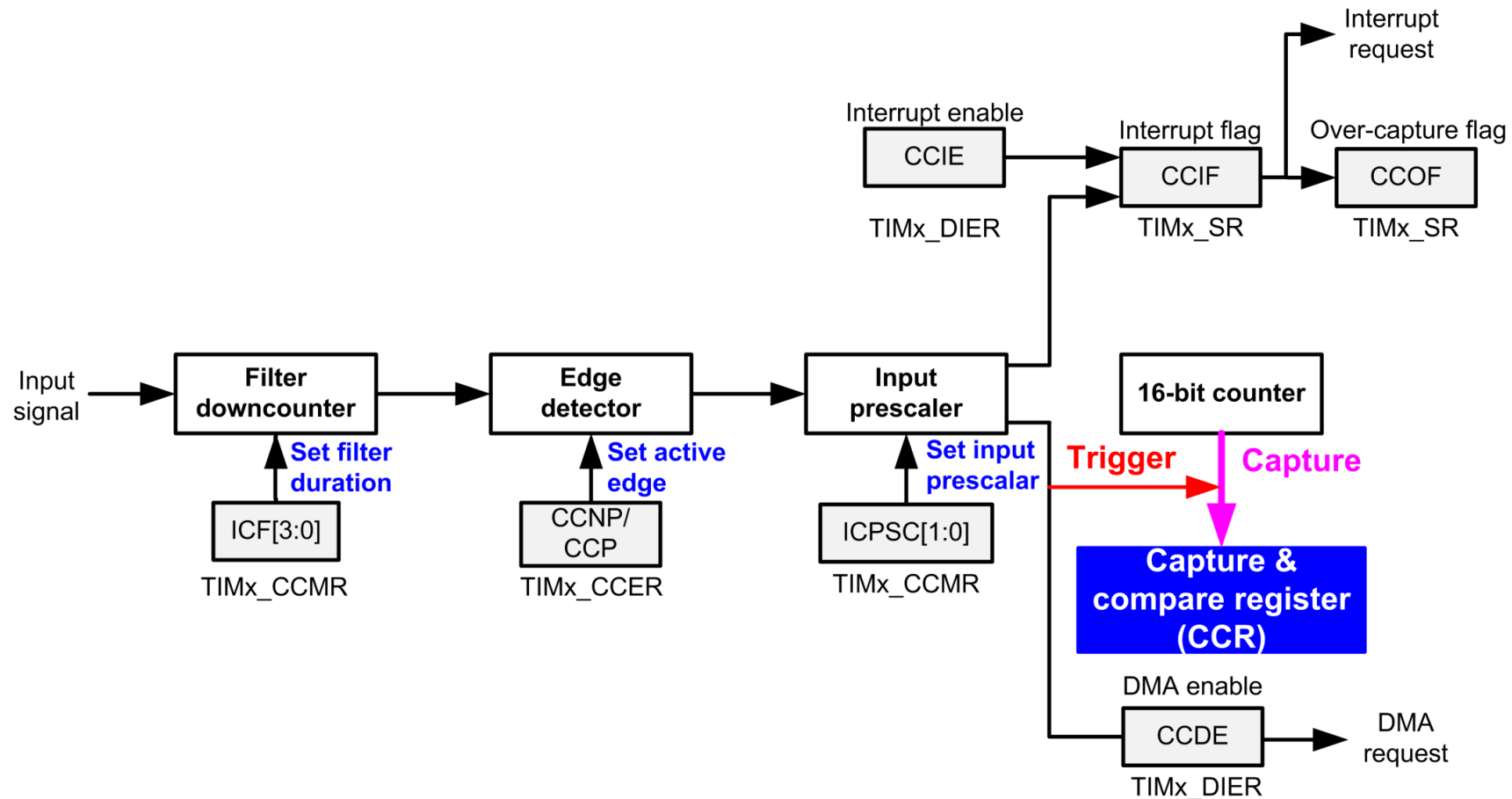

Input Filtering

Figure from: Yifeng Zhu, Embedded Systems with ARM Cortex-M Microcontrollers in Assembly Language and C

- Digital filter for debouncing and noise removal

- N consecutive

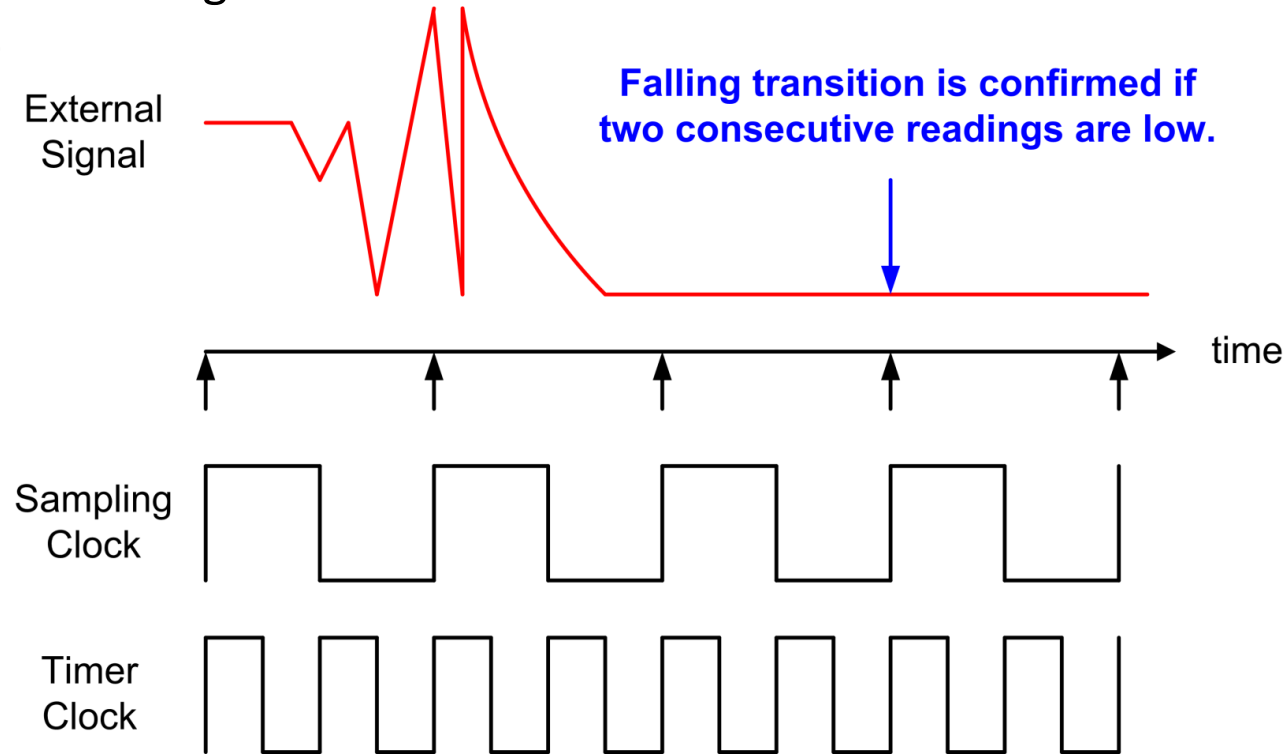

Filter acceptance = 2

Input Prescaler

Figure from: Yifeng Zhu, Embedded Systems with ARM Cortex-M Microcontrollers in Assembly Language and C

- Assume capture only rising edge

External
Signal

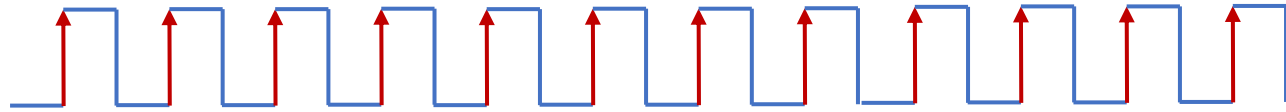

Capture every
rising edge

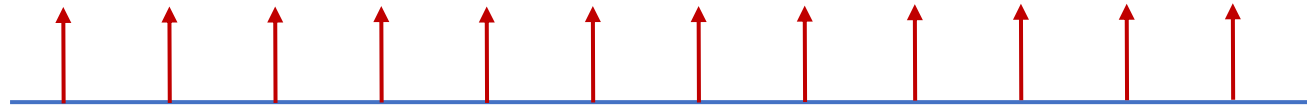

Capture every
2 rising edges



Capture every
4 rising edges



Output Compare

Slide from: Yifeng Zhu, Embedded Systems with ARM Cortex-M Microcontrollers in Assembly Language and C

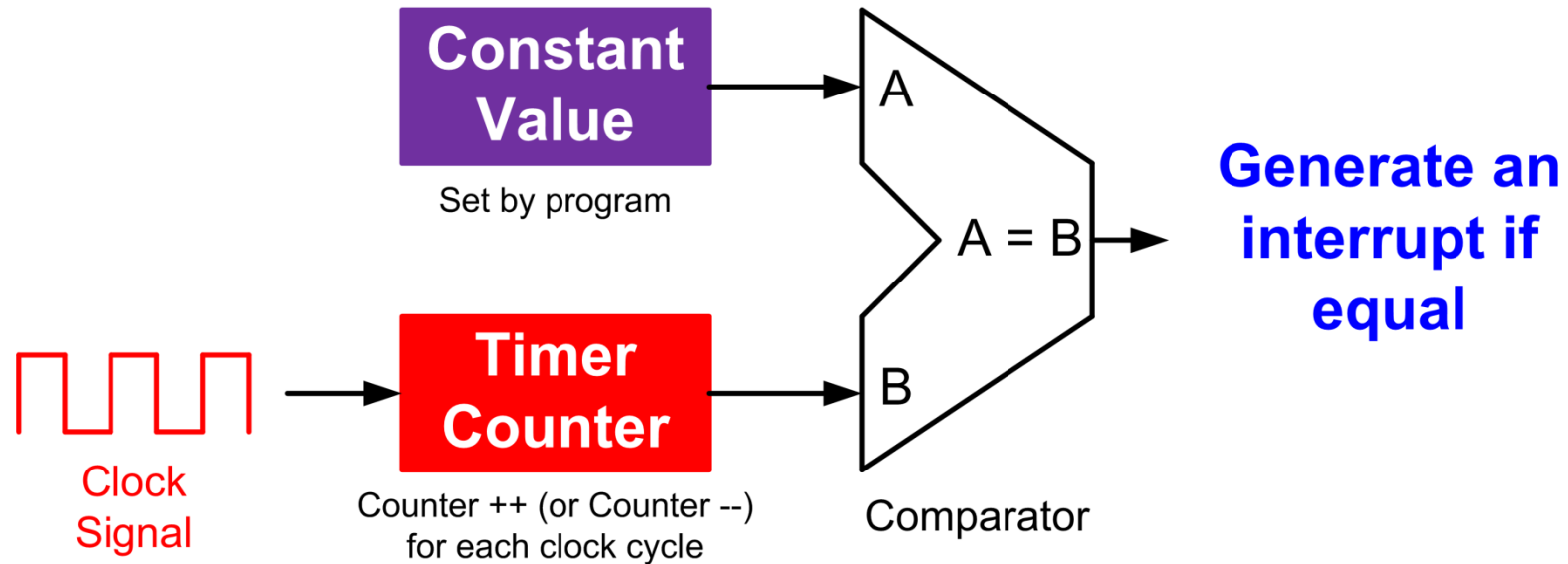

Output Compare (Active Mode)

Figure adapted from: Yifeng Zhu, Embedded Systems with ARM Cortex-M Microcontrollers in Assembly Language and C

Upcounting mode, ARR = 6, CCR = 3

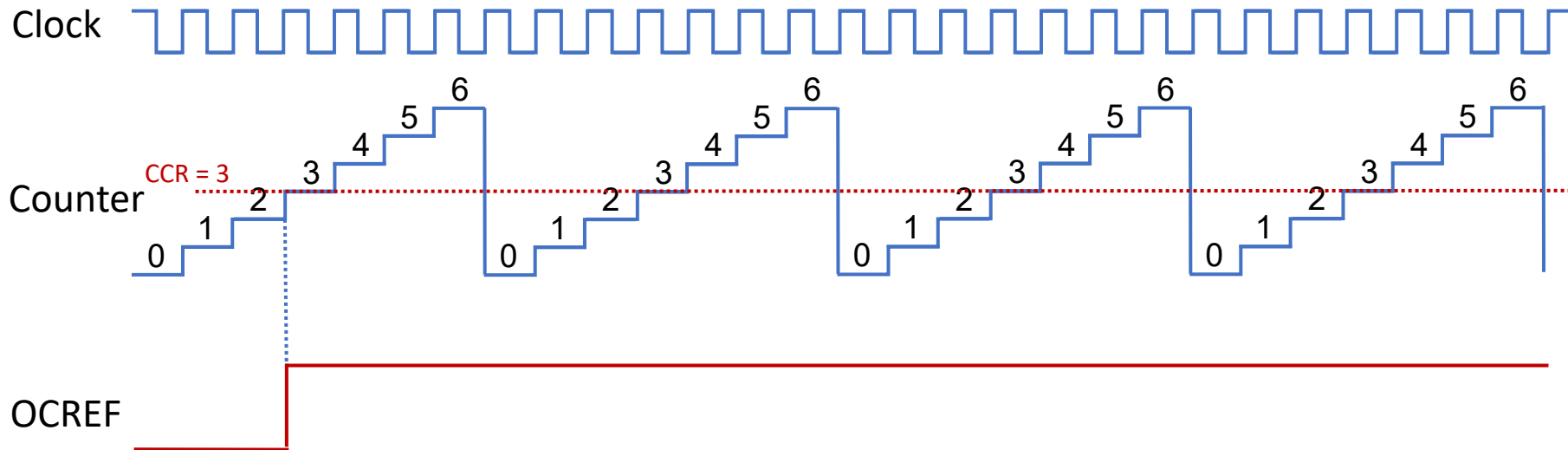

Active Mode

Timer Output (OCREF) = High if counter == CCR

Output Compare (Inactive Mode)

Figure adapted from: Yifeng Zhu, Embedded Systems with ARM Cortex-M Microcontrollers in Assembly Language and C

Upcounting mode, ARR = 6, CCR = 3

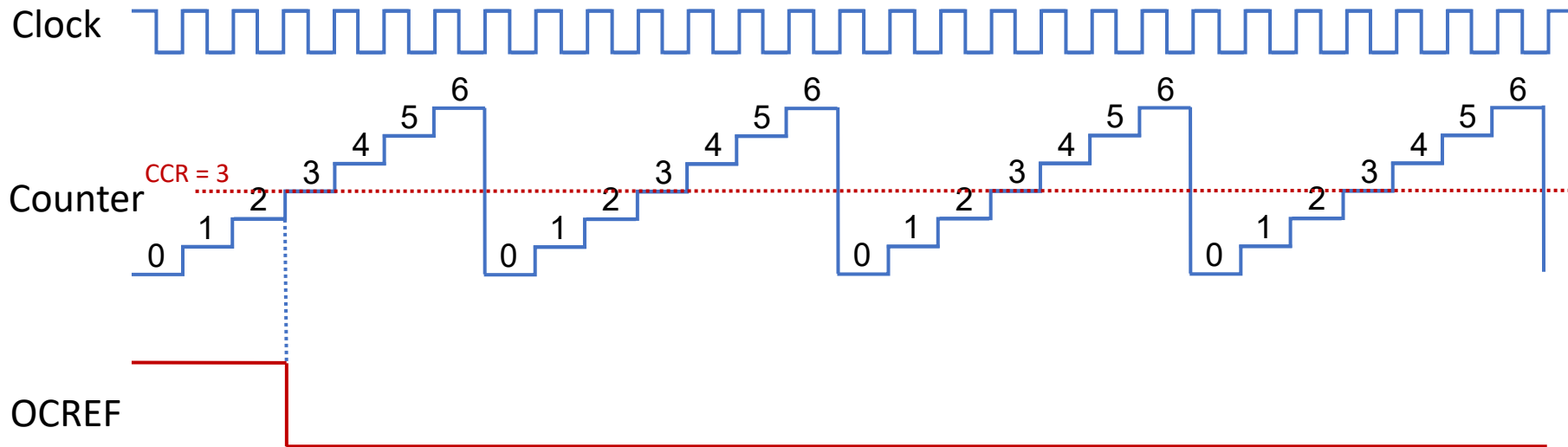

Inactive Mode

Timer Output (OCREF) = Low if counter == CCR

Output Compare (Toggle Mode)

Figure adapted from: Yifeng Zhu, Embedded Systems with ARM Cortex-M Microcontrollers in Assembly Language and C

Upcounting mode, ARR = 6, CCR = 3

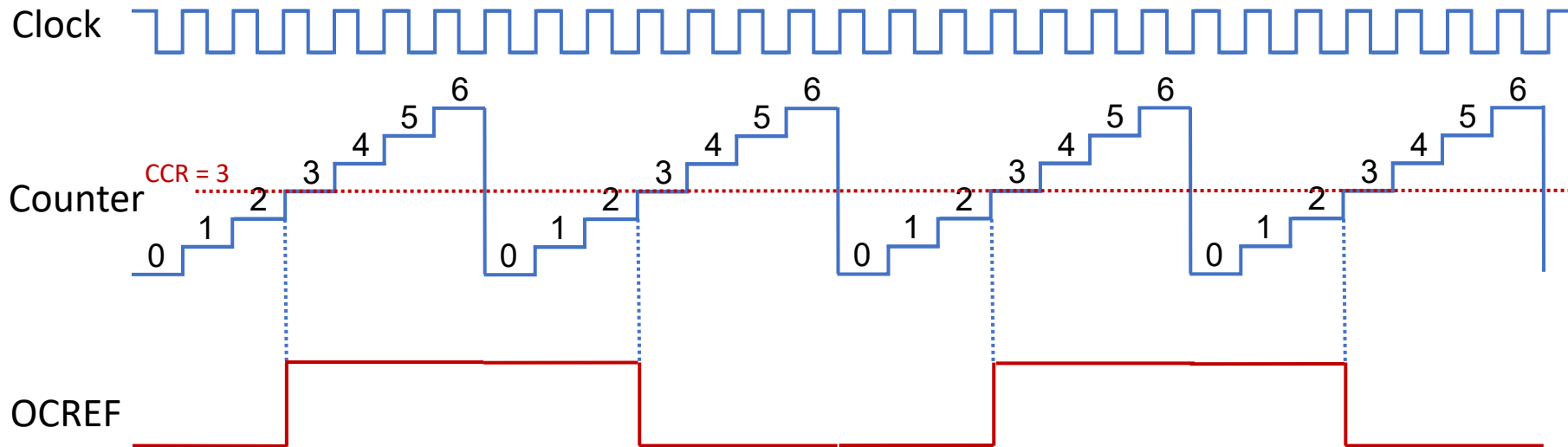

Toggle Mode

Timer Output (OCREF) = Toggle if counter == CCR

Multi-Channel Outputs

Figure adapted from: Yifeng Zhu, Embedded Systems with ARM Cortex-M Microcontrollers in Assembly Language and C

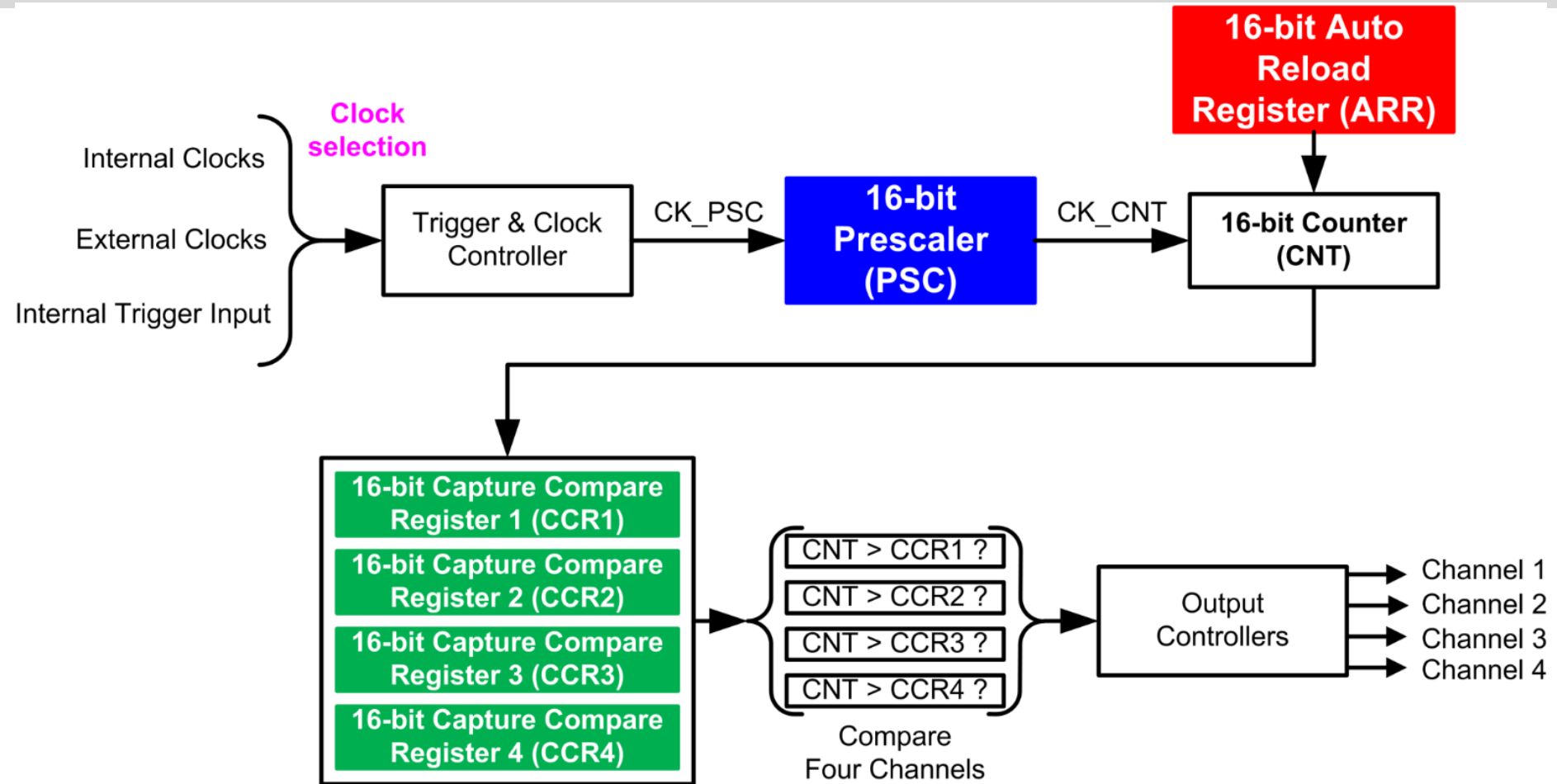

STM32 Timers

Figure 197. General-purpose timer block diagram

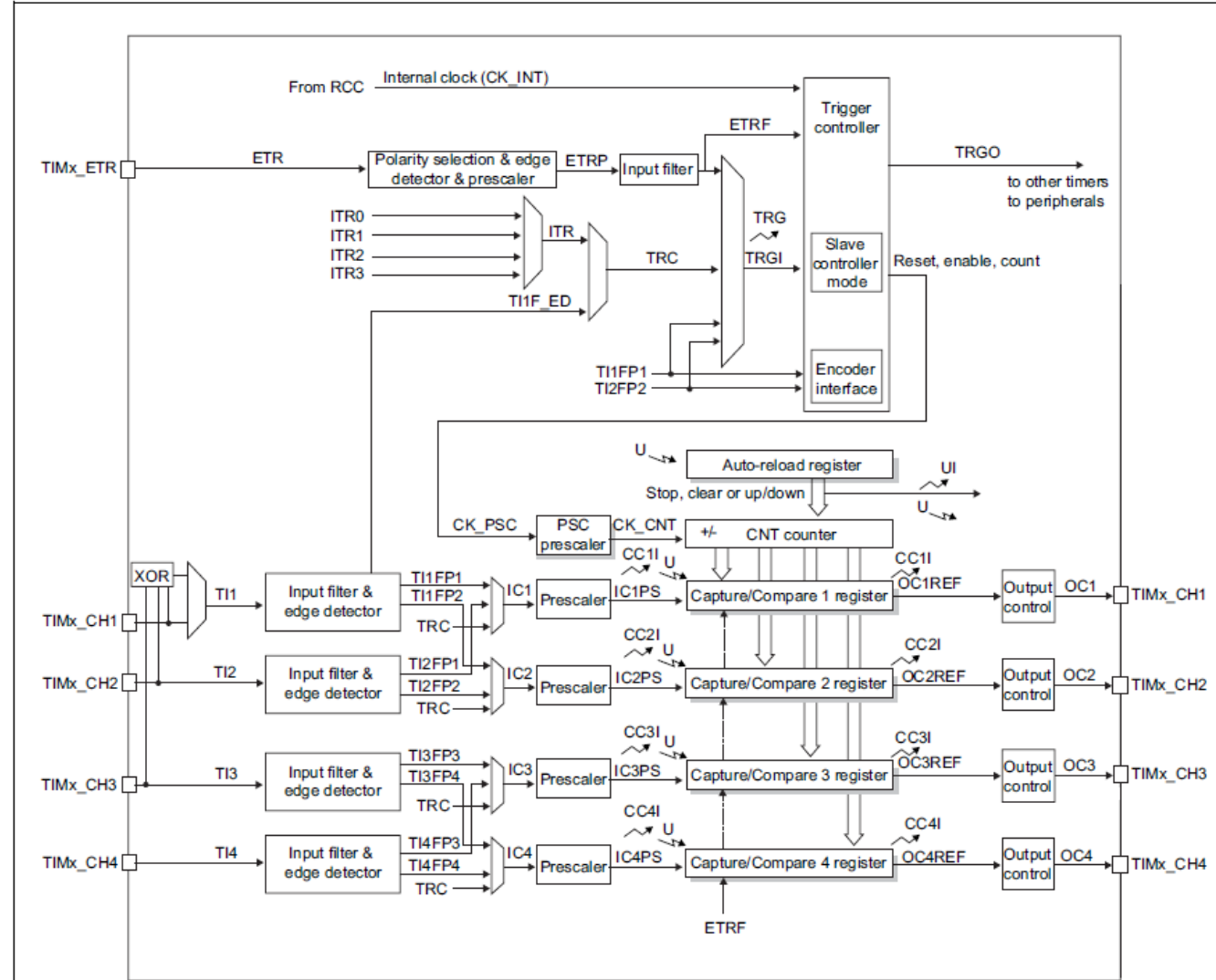

Notes:
 [Reg] Preload registers transferred to active registers on U event according to control bit
 ↗ Event
 ↘ Interrupt & DMA output

22.2 TIM6/TIM7 main features

Basic timer (TIM6/TIM7) features include:

- 16-bit auto-reload upcounter
- 16-bit programmable prescaler used to divide (also “on the fly”) the counter clock frequency by any factor between 1 and 65535
- Synchronization circuit to trigger the DAC
- Interrupt/DMA generation on the update event: counter overflow

Figure 247. Basic timer block diagram

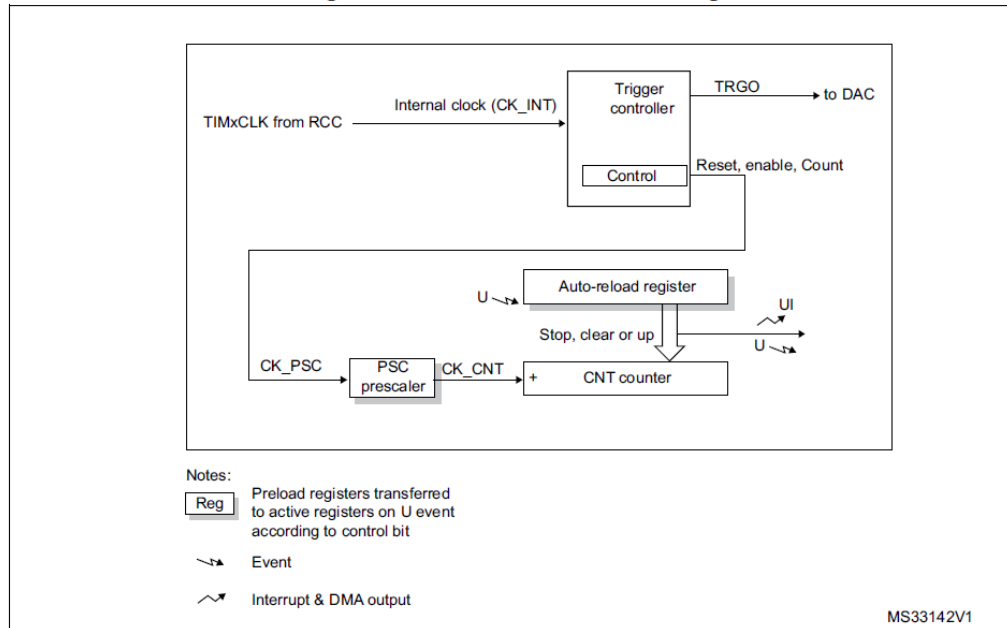

Notes:
 [Reg] Preload registers transferred to active registers on U event according to control bit
 ↗ Event
 ↘ Interrupt & DMA output

Real-time Clock

- RTC is a digital clock that provides calendar time and date.
- The RTC on STM32F303 supports:
 - Calendar with subsecond, seconds, minutes, hours (12 or 24 format), weekday, date, month, year, in BCD (binary-coded decimal) format
 - Two programmable alarms with wake-up from Stop and Standby mode capability.



https://wiki.st.com/stm32mcu/wiki/Getting_started_with_RTC

Learning Resources

“Embedded Systems with ARM Cortex-M Microcontrollers in Assembly Language and C (Fourth Edition)” – Yifeng Zhu

- General purpose timers - chapter 16

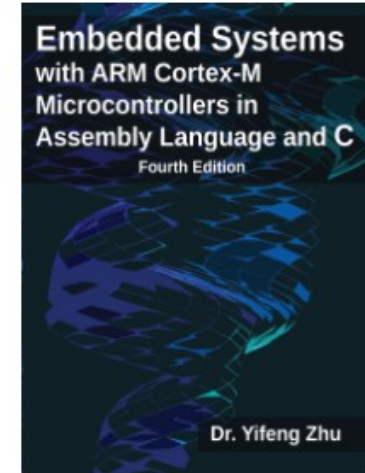

System Timer (SysTick)

Slide adapted from: Yifeng Zhu, Embedded Systems with ARM Cortex-M Microcontrollers in Assembly Language and C

- Generate **SysTick interrupts** at a fixed time interval

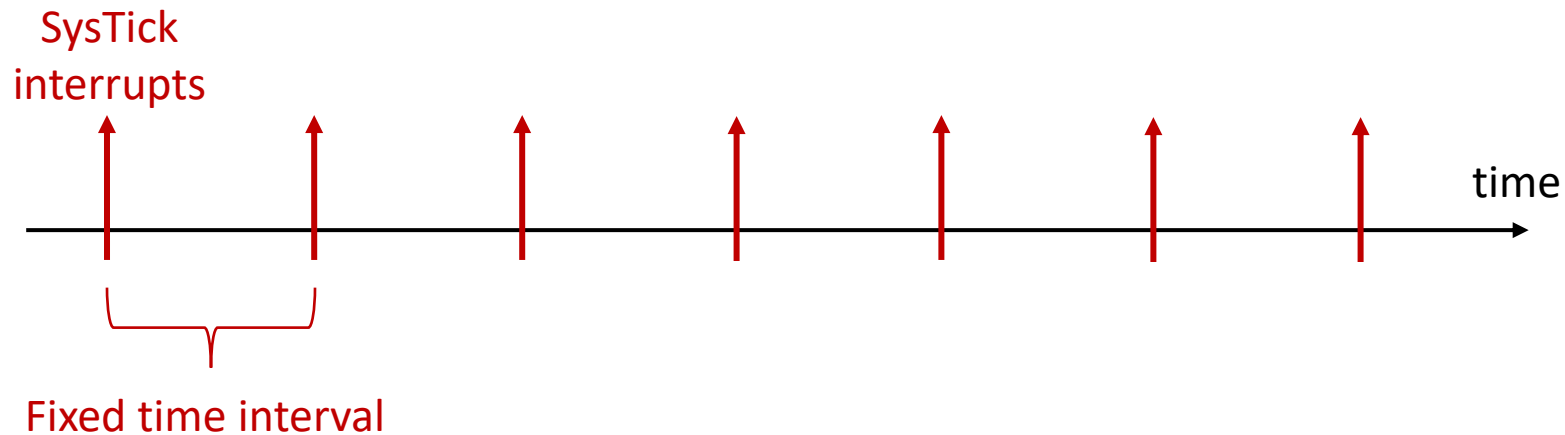

- Example Usages:
 - Measuring time elapsed, such as time delay function
 - Executing tasks periodically, such as periodic polling, and OS CPU scheduling

Diagram of System Timer (SysTick)

Slide adapted from: Yifeng Zhu, Embedded Systems with ARM Cortex-M Microcontrollers in Assembly Language and C

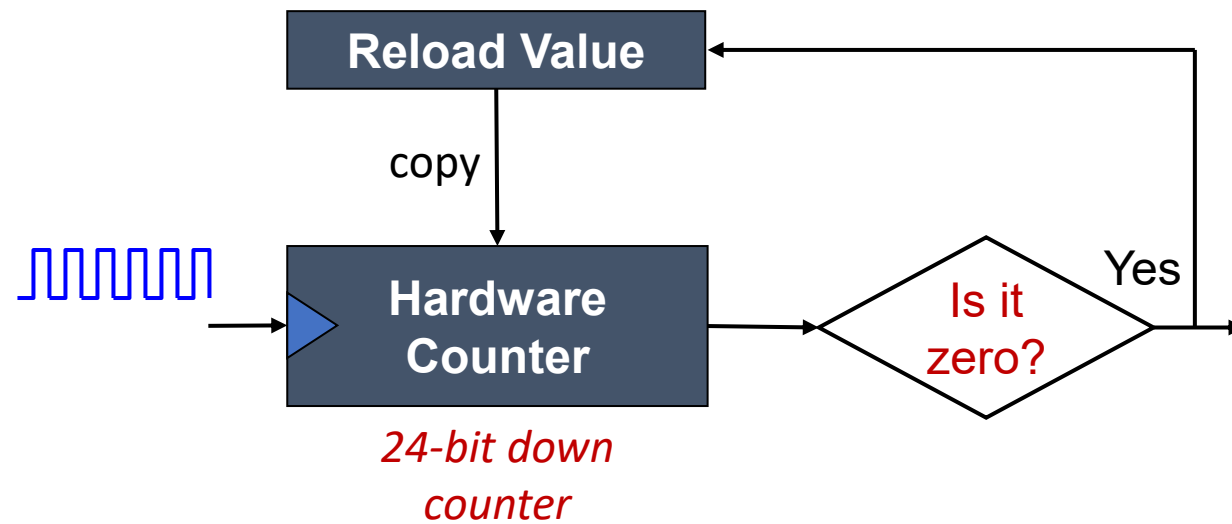

System Timer

Slide adapted from: Yifeng Zhu, Embedded Systems with ARM Cortex-M Microcontrollers in Assembly Language and C

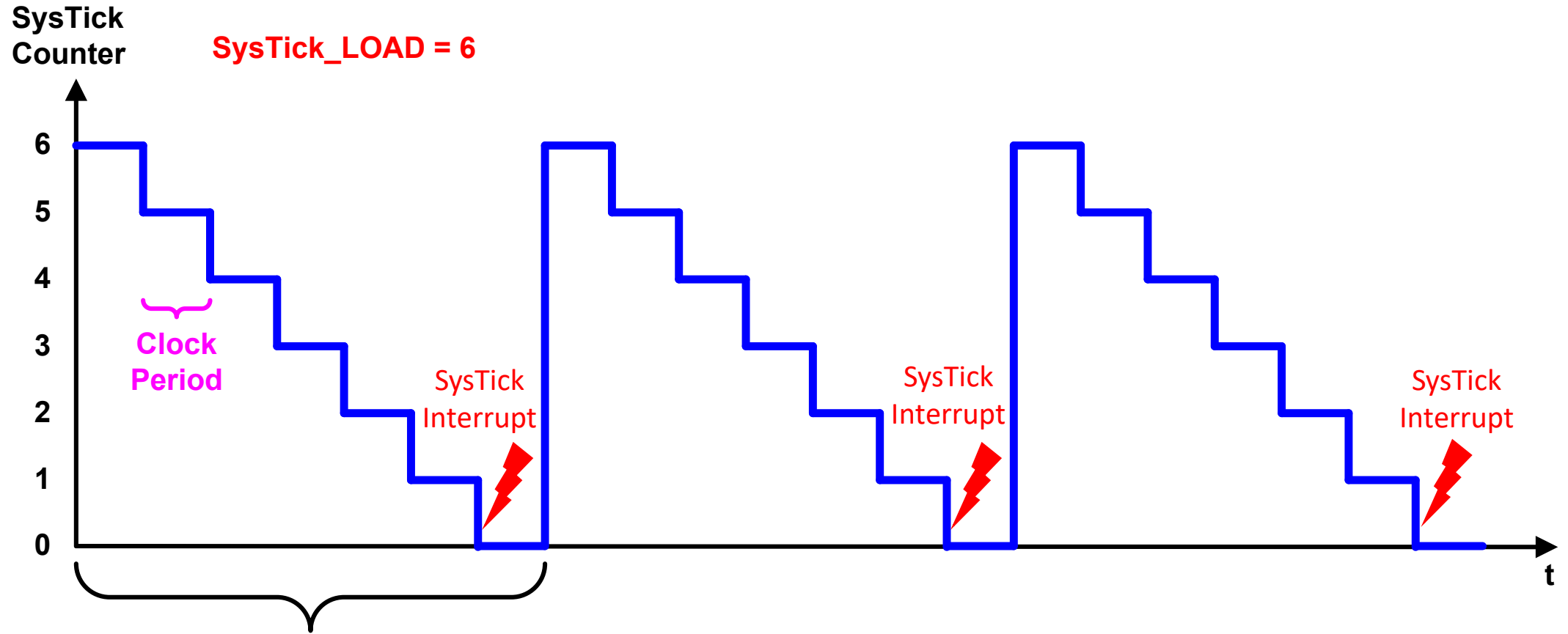

SysTick Interrupt Time Period = (SysTick_LOAD + 1) × Clock Period = 7 × Clock Period

Learning Resources

“Embedded Systems with ARM Cortex-M Microcontrollers in Assembly Language and C (Fourth Edition)” – Yifeng Zhu

- Interrupts: System Timer - chapter 11

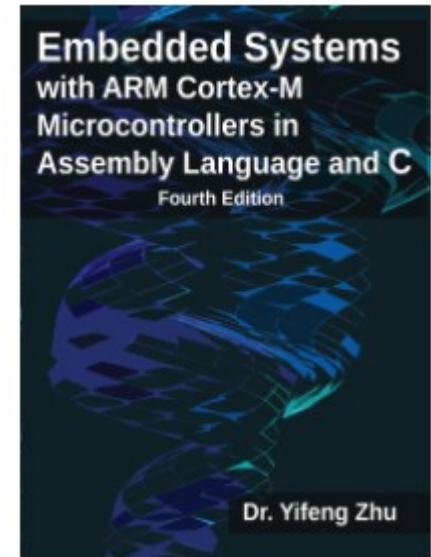

Watchdog Timer

- a timer that monitors microcontroller programs to see if they are out of control or have stopped operating
- Keep refreshing the watchdog timer's counter
- If not refreshed before timeout, the processor will reset

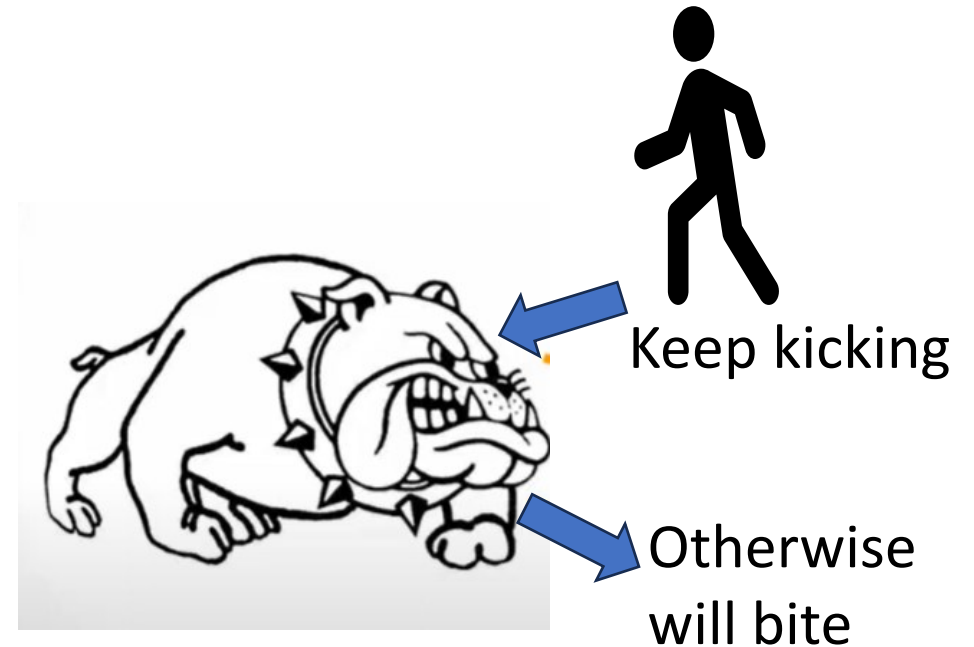

https://wiki.st.com/stm32mcu/wiki/Getting_started_with_WDG